

REFERENCE

REF: 113100005

EAN: 8434778022339

FEATURES

Built-in hood
 Electronic control
 Rim extraction
 3 speeds + 1 intensive
 Free Outlet exhaust capacity (m³/h): 735
 Max speed exhaust capacity (m³/h): 738
 Intensive speed sound level (dBA): 70,1
 Max speed sound level (dBA): 68
 Min speed sound level (dBA): 54,4
 2 LED Lamps
 1 aluminium filter
 Stop delay timer
 Anti-return valve included
 Outlet reduction included
 Optional Charcoal Filter: D4C

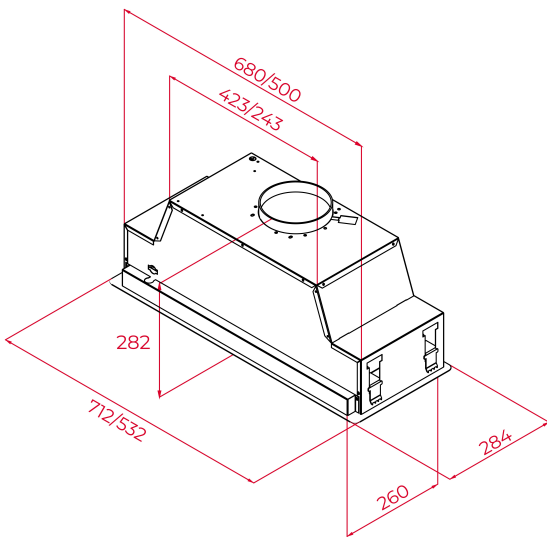

LED

Perimeter
extractionStop Delay
Timer

DIMENSIONS

Product height (mm): 282

Product width (mm): 532

Product depth (mm): 284

Product length (mm):

Net weight (Kg): 9,8

TECH SPECS

Energy Efficiency Class: A+

Noise (LwA) Min Speed (dB): 54,4

Noise (LwA) Max Speed (dB): 68

Noise (LwA) Boost Speed (dB): 70,1

Ø Outlet (mm): 150

COLOURS