



User Guide

Quality, Design and Innovation





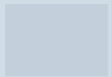

















home.liebherr.com/fridge-manuals



LIEBHERR

Contents

1	The appliance at a glance.....	3		Language.....	13
1.1	Delivered contents.....	3		Info.....	14
1.2	Overview of the appliance and its equipment.....	3		Reminder.....	14
1.3	SmartDevice.....	3		Reset.....	14
1.4	Range of appliance use.....	4			
1.5	Conformity.....	4			
1.6	EPREL Database.....	4			
2	General safety instructions.....	4			
3	Start-up.....	6			
3.1	Turning on the appliance.....	6		6.4 Error messages.....	14
3.2	Insert the equipment.....	6		6.4.1 Warnings.....	14
				6.4.2 Message.....	14
				6.4.3 DemoMode.....	14
4	Food management.....	6			
4.1	Storing food.....	6		7	Equipment.....
4.2	Storage times.....	7		7.1	4-star freezer*.....
				7.2	Door racks.....
				7.3	Shelves.....
				7.4	Split shelf.....
				7.5	VarioSafe*.....
				7.6	InfinitySpring*.....
				7.7	Space for baking tray.....
				7.8	Variable bottle shelf.....
				7.9	Drawers.....
				7.10	Fruit & Vegetable-Safe cover.....
				7.11	Humidity control.....
				7.12	HydroBreeze*.....
				7.13	Accessories.....
5	Energy saving.....	8		8	Maintenance.....
6	Use.....	8		8.1	FreshAir carbon filter.....
6.1	Controls and displays.....	8		8.2	Water tank*.....
6.1.1	Status display.....	8		8.3	Water filter*.....
6.1.2	Navigation.....	9		8.4	Disassembling / assembling pull-out systems.....
6.1.3	Display symbols.....	9		8.5	Defrosting the appliance.....
6.2	Operating logic.....	9		8.6	Defrosting the freezer compartment manually*....
6.2.1	Activating/deactivating settings.....	9		8.7	Cleaning the appliance.....
6.2.2	Selecting function value.....	9		9	Customer support.....
6.2.3	Activating/deactivating settings.....	9		9.1	Technical specifications.....
6.2.4	Selecting the setting value.....	10		9.2	Operating noises.....
6.2.5	Calling up the customer menu.....	10		9.3	Technical faults.....
6.3	Functions.....	10		9.4	Customer service.....
	Turn off appliance.....	10		9.5	Rating plate.....
	WiFi.....	10		10	Decommissioning.....
	Temperature.....	11		11	Disposal.....
	BioFresh B-Value.....	11		11.1	Preparing appliance for disposal.....
	C-Value*.....	11		11.2	Disposing of the appliance in an environmentally friendly manner.....
	D-Value.....	11			
	SuperCool.....	11			
	PartyMode.....	12			
	HolidayMode.....	12			
	SabbathMode.....	12			
	EnergySaver.....	12			
	HydroBreeze*.....	13			
	CleaningMode.....	13			
	Display brightness.....	13			
	Door alarm.....	13			
	Entry lock.....	13			

The manufacturer is constantly working to improve all types and models. Therefore, please be aware that we reserve the right to make changes to the shape, equipment and technology.

Symbol	Explanation
	Read instructions Please read the information in these instructions carefully to understand all of the benefits of your new appliance.

Symbol	Explanation
	<p>Full instructions on the internet</p> <p>You can find detailed instructions on the internet using the QR code on the front of these instruction or by entering the service number at home.liebherr.com/fridge-manuals.</p> <p>The service number can be found on the serial tag:</p> <p><i>Fig. Example illustration</i></p>
	<p>Check appliance</p> <p>Check all parts for transport damage. If you have any complaints, please contact your agent or customer service.</p>
	<p>Differences</p> <p>These instructions apply to a range of models, so there may be differences. Sections that apply to certain models only are indicated by an asterisk (*).</p>
	<p>Instructions and results</p> <p>Instructions are marked with a ▶.</p> <p>Results are marked with a ▷.</p>
	<p>Videos</p> <p>Videos about the appliances are available on the YouTube channel of Liebherr-Hausgeräte.</p>

These operating instructions apply to:

IRBb / d / e	40.. / 41.. / 45.. / 48.. / 51..
IRBdi	51..

1 The appliance at a glance

1.1 Delivered contents

Check all parts for damage during transport. If you have any complaints, please contact the dealer or Customer Service (see 9.4 Customer service).

Delivery contains the following parts:

- Integrated appliance
- Equipment (depending on your model)
- Installation parts (depending on your model)
- "Quick Start Guide"
- "Installation Guide"*
- Service brochure

1.2 Overview of the appliance and its equipment

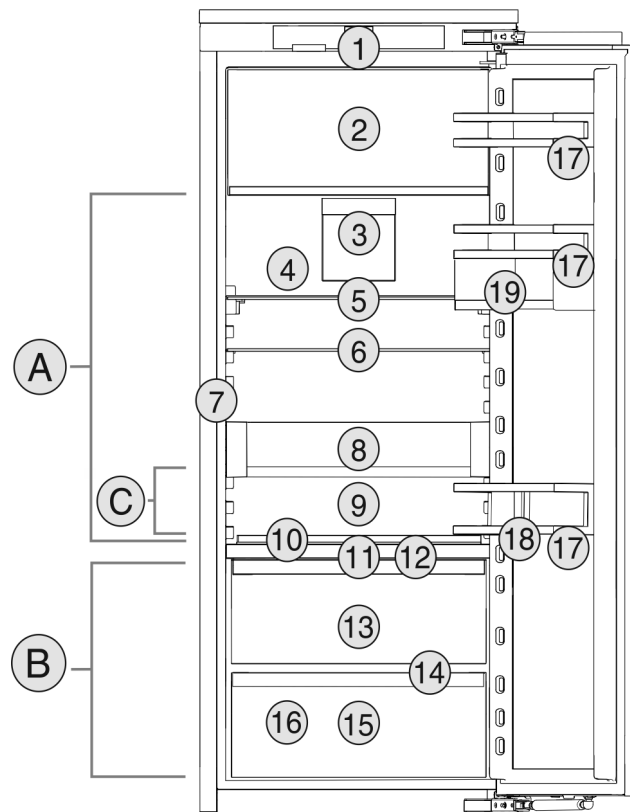

Fig. 1 Exemplary illustration

Temperature zone

- (A) Fridge
(B) BioFresh
(C) Coldest zone

Equipment

- | | |
|--------------------------------------------|-------------------------------------|
| (1) Controls | (11) HydroBreeze* |
| (2) 4-star freezer* | (12) Lid for Fruit & Vegetable-Safe |
| (3) Fan with FreshAir active carbon filter | (13) Fruit & Vegetable-Safe |
| (4) Dry rear panel | (14) Drainage outlet |
| (5) Split shelf | (15) Meat & Dairy-Safe |
| (6) Shelf | (16) Rating plate |
| (7) InfinitySpring* | (17) Door racks |
| (8) VarioSafe* | (18) Bottle rack |
| (9) Space for baking tray | (19) VarioBoxes* |
| (10) Variable bottle shelf | |

Note

- ▶ The shelves, drawers, and baskets are arranged for optimal energy efficiency in the factory configuration. However, changes to the arrangement within the given insertion options – for example the arrangement of shelves in the fridge compartment – have no effect on energy consumption.

1.3 SmartDevice

SmartDevice is the networking solution for your refrigerator. If your appliance is SmartDevice-enabled or compatible, you can quickly and easily connect your appliance to your WiFi. With the SmartDevice app, you can operate your appliance from a mobile device. Additional functions and setting options are available in the SmartDevice app.

General safety instructions

SmartDevice-enabled appliance:* Your appliance is equipped with the SmartDeviceBox. In order to connect your appliance to the WiFi, you need to download the SmartDevice app.*

SmartDevice-compatible appliance:* Your appliance is compatible for use with the SmartDeviceBox. You must first purchase and install the SmartDeviceBox. In order to connect your appliance to the WiFi, you need to download the SmartDevice app.*



More information about SmartDevice: smartdevice.liebherr.com

Purchase the SmartDeviceBox in the Liebherr-Hausgeräte store:* home.liebherr.com/shop/de/deu/smartdevicebox.html*

Downloading the SmartDevice app:



After installing and configuring the SmartDevice app, you can connect your appliance to the WiFi using the SmartDevice app and the WiFi appliance function (see WiFi).

Note

You cannot use the SmartDeviceBox in the following countries: Russia, Belarus, Kazakhstan. The SmartDevice function is not available.

1.4 Range of appliance use

Normal use

The appliance is only suitable for cooling food for residential or other similar environments. This includes the following types of uses

- in staff kitchens, bed and breakfasts,
- by guests in country homes, hotels, motels and other types of accommodations,
- for catering and similar wholesale services.

The appliance is not suitable for freezing food;*

All other types of uses are not permitted.

Foreseeable misuse

The following uses are specifically prohibited:

- Storage and cooling of medication, blood plasma, laboratory preparations or similar substances and products in accordance with the Medical Device Directive 2007/47/EC
- Use in areas at risk of explosion

Incorrect appliance use can cause damage to the stored products or cause them to spoil.

Climate ratings

The appliance is set to operate within specific ambient temperature limits according to its climate rating. The climate rating for your appliance is printed on the rating plate.

Note

► To guarantee trouble-free operation, comply with the indicated ambient temperatures.

Climate rating	for ambient temperatures from
SN	10 °C to 32 °C
N	16 °C to 32 °C
ST	16 °C to 38 °C
T	16 °C to 43 °C
SN-ST	10 °C to 38 °C
SN-T	10 °C to 43 °C

1.5 Conformity

The refrigerant circuit has been tested for leaks. When installed, the appliance complies with the applicable safety regulations and with the corresponding directives.

For the EU market:* The appliance complies with directive 2014/53/EU.*

For the GB market:* The appliance complies with the Radio Equipment Regulations 2017 SI 2017 No. 1206.*

The full text of the EU Declaration of Conformity is available on the following website: www.liebherr.com

The BioFresh compartment meets the requirements of a cold storage compartment as set out in DIN EN 62552:2020.

1.6 EPREL Database

Details about energy labeling and ecodesign requirements will be available on the European product database (EPREL) from March 1, 2021. You can access the product database at the following link: <https://eprel.ec.europa.eu/> You will be asked to enter the model ID. You can find the model ID on the type plate.

2 General safety instructions

Please keep these operating instructions in a safe place so you can refer back to them at any time.

If you pass the appliance on, please hand these operating instructions to the new owner.

Read these operating instructions before use in order to use the appliance safely and correctly. Follow the instructions, safety instructions and warning messages included

at all times. They are important for ensuring you can operate and install the appliance safely and without any problems.

Dangers for the user:

- This appliance can be operated by children as well as by persons with reduced physical, sensory or mental capabilities or lack of experience and knowledge if they are supervised or have been instructed in the safe use of the appliance and understand the associated risks. Children must not play with the appliance. Cleaning and user maintenance must not be performed by children unless they are supervised. Children between the ages of 3 and 8 may load and unload the appliance. Children under the age of 3 must be kept away from the appliance if they are not constantly supervised.
- The socket must be easily accessible so that the appliance can be disconnected quickly from the electricity in an emergency. It must not be located in the area behind the appliance.
- When disconnecting the appliance from the outlet, always take hold of the plug. Do not pull on the cable.
- Disconnect the power plug or switch off the power if a fault occurs.
- Do not damage the mains power line. Do not operate the appliance from a defective mains power line.
- Repairs and work on the appliance may only be carried out by after sales service or other specifically trained qualified personnel.
- Only install, connect and dispose of the appliance in accordance with the instructions.
- Only operate the appliance after it has been installed.
- The manufacturer is not liable for damage arising from incorrect connection to the water supply.*

Risk of fire:

- The refrigerant contained within the appliance (specifications on the rating plate) is environmentally friendly, but flammable. Leaking refrigerant can ignite.
 - Do not damage the pipes of the refrigerant circuit.
 - Do not handle ignition sources inside the appliance.

- Do not use electrical devices inside the appliance (e.g. steam cleaners, heaters, ice cream makers, etc.).
- If refrigerant leaks: Remove naked flames or ignition sources located near the area of the leak. Air the room well. Contact the customer service department.
- Do not store explosive materials or spray cans with flammable propellants, such as e.g. butane, propane, pentane, etc. in the appliance. You can recognize such spray cans by the printed contents or a flame symbol. Any leaking gasses can be ignited by electrical components.
- Keep lit candles, lamps and other objects with naked flames away from the appliance so they do not cause a fire.
- Alcoholic beverages or other containers holding alcohol must always be tightly sealed for storage purposes. Any leaking alcohol can be ignited by electrical components

Tipover hazard:

- Do not stand or climb on the base, drawers, doors, etc. This applies in particular to children.

Risk of food poisoning:

- Do not consume food that has passed its best before date.

Danger of frostbite, feelings of numbness and pain:

- Avoid prolonged skin contact with cold surfaces or chilled/frozen food or take protective measures, e.g. wear gloves.

Risk of injury and damage:

- Hot steam may lead to injuries. Do not use any electrical heating or steam cleaning equipment, naked flames or defrosting sprays for defrosting
- Do not remove ice with sharp objects

Risk of crushing:

- Do not reach into the hinge when opening and closing the door. Fingers may get trapped.

Symbols on the device:



The symbol can be on the compressor. It refers to the oil in the compressor and refers to the following danger: Can be lethal if swallowed or inhaled. This notice only applies for recycling. There is no danger during normal operation.

Start-up



The symbol is located on the compressor and indicates the danger of inflammable materials. Do not remove the label.



This label or a similar one can be located on the rear of the appliance. It refers to the foamed-in panels in the door and/or the housing. This notice only applies for recycling. Do not remove the label.

Observe the warning messages and other detailed information in the other sections:

	DANGER	indicates a hazardous situation, which if not avoided, will result in death or serious injury.
	WARNING	indicates a hazardous situation, which if not avoided, could result in death or serious injury.
	CAUTION	indicates a hazardous situation, which if not avoided, will result in minor or moderate injury.
	NOTICE	indicates a hazardous situation, which if not avoided, could result in damage to property.
	Note	indicates useful advice and tips.

3 Start-up

3.1 Turning on the appliance

Make sure that the following requirements are met:

- Appliance is installed and connected according to installation instructions.
- All adhesive strips, adhesive and protective films, as well as transport safety devices in and on the appliance are removed.
- All advertising material has been removed from the drawers.

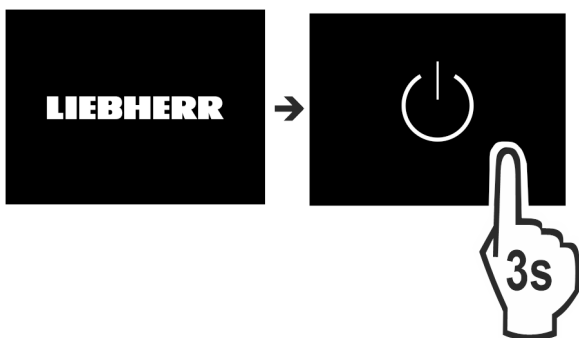

Fig. 2

- ▶ Switch on the appliance using the display.



Fig. 3

- ▶ Select the language.
- ▷ The status display appears.

The appliance starts in DemoMode:

If the appliance starts in DemoMode, you can deactivate DemoMode within the next 5 minutes.

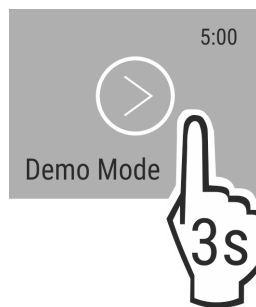

Fig. 4

- ▶ Press DemoMode for 3 seconds.
- ▷ DemoMode is deactivated.

Note

The manufacturer recommends:

- ▶ Place the food inside: Wait for around 6 hours until the set temperature is reached.
- ▶ **Store frozen foods** at -18 °C or colder.*

3.2 Insert the equipment

Note

Accessories can be purchased from the Liebherr-Hausgeräte store at home.liebherr.com/shop/de/deu/zubehor.html.

- ▶ Insert the supplied equipment to help you make the most of the appliance.
- ▶ Insert the water tank (see 8.2.2 Inserting the water tank).*
- ▶ Insert the water filter (see 8.3.2 Installing the water filter).*
- ▶ Insert the drip tray (see 8.2.3 Removing / inserting the drip tray).*

4 Food management

4.1 Storing food



WARNING

Danger of fire

- ▶ Do not use electrical appliances inside the food storage compartments of the appliance, unless they are of the type recommended by the manufacturer.

Note

Insufficient ventilation results in an increase in energy consumption and reduction of the refrigerating performance
 ► Always keep the air slots unobstructed.

When storing food, remember these basic rules:

- Do not obstruct the air vents on the back wall.
- Do not obstruct the air vents on the fan.
- Food is well sealed.
- Food that easily absorbs or emits odor or taste, are in sealed containers or are covered.
- Raw meat or fish is in clean, sealed containers so that other food cannot be touched or drip on them.
- Liquids are in sealed containers.
- Food is stored spaced apart to ensure good air circulation.

Note

Failure to follow these guidelines can lead to food perishing.

4.1.1 Fridge

The natural air circulation means the temperature varies in different sections.

Arranging the food:

- In the top section and in the door: butter and cheese, preserves, and tubes.
- The coldest zone *Fig. 1 (C)* is for: easily perishable food such as prepared meals.

4.1.2 BioFresh

BioFresh allows some fresh food to be stored longer compared to conventional cooling.

Food with a "use by" date must still be consumed by the date indicated on the package

Note

If the temperatures drop below 0 °C foods may freeze to each other.

- Store cold-sensitive vegetables such as cucumbers, aubergines, zucchini, and cold-sensitive tropical fruit, in the refrigerator compartment.

Fruit & Vegetable-Safe

This provides a fresh storage climate with the lid closed. A moist climate is suitable for storing unsealed food with a high moisture content (e.g. salad, vegetables, fruit).

The humidity depends on the moisture content of the stored items and how frequently the door is opened. You can regulate the moisture.

Arranging the food:

- Place unsealed fruit and vegetables.
- Excessive moisture: Regulate the air humidity (see 7.11 Humidity control).

Meat & Dairy-Safe

The DrySafe provides a relatively dry storage environment. A dry climate is suitable for dry or sealed food (e.g. dairy products, meat, fish, sausage).

Arranging the food:

- Place dry or sealed food.

4.1.3 Freezer compartment*

The air temperature in the compartment, which is measured with a thermometer or other measurement devices, can fluctuate. Temperature fluctuations are greater in a half-full or empty compartment, and temperatures can reach -18 °C and above.

Freezing food

You can freeze as many kilograms of fresh food within 24 hours as indicated on the nameplate under "Freeze capacity ... kg/24h".

To ensure that the food freezes quickly to the core, keep to the following quantities per pack:

- Fruit, vegetables up to 1 kg
- Meat up to 2.5 kg

Before freezing, please note the following:*

- For maximum freezing capacity: Glass plate is removed.

Arranging the food:



CAUTION

There is a risk of injury from pieces of broken glass! Bottles and cans containing drinks can split or crack when frozen. This applies in particular to carbonated drinks.

- Do not freeze bottles and cans containing drinks

- Place sealed food in the freezer so that it is in contact with the floor or the side walls.

Defrosting food

- in the fridge compartment
- in the microwave
- in the oven/fan oven
- at room temperature



WARNING

Danger of food poisoning!

- Do not re-freeze defrosted food.

- Remove only the food you need for now.
- Use defrosted food as quickly as possible

4.2 Storage times

The storage times given are guidelines

Food with a "use by" date must still be consumed by the date indicated on the package

4.2.1 Fridge

The best-before date stated on the packaging applies.

4.2.2 BioFresh

Guideline storage times for the Meat & Dairy-Safe		
Butter	at 1 °C	up to 90 days
Hard cheese	at 1 °C	up to 110 days
Milk	at 1 °C	up to 12 days
Sausage, cold cuts	at 1 °C	up to 8 days
Poultry	at 1 °C	up to 6 days
Pork	at 1 °C	up to 6 days
Beef	at 1 °C	up to 6 days
Game	at 1 °C	up to 6 days

Note

- Note that higher-protein foods spoil more quickly So, shellfish and crustaceans perish faster than fish, and fish perishes faster than meat.

Energy saving

Guideline storage times for the Fruit & Vegetable-Safe		
Vegetables, lettuce		
Artichokes	at 1 °C	up to 14 days
Celery	at 1 °C	up to 28 days
Cauliflower	at 1 °C	up to 21 days
Broccoli	at 1 °C	up to 13 days
Endives	at 1 °C	up to 27 days
Mâche	at 1 °C	up to 19 days
Peas	at 1 °C	up to 14 days
Kale	at 1 °C	up to 14 days
Carrots	at 1 °C	up to 80 days
Garlic	at 1 °C	up to 160 days
Cabbage turnip	at 1 °C	up to 14 days
Iceberg lettuce	at 1 °C	up to 13 days
Herbs	at 1 °C	up to 13 days
Leeks	at 1 °C	up to 29 days
Mushrooms	at 1 °C	up to 7 days
Radishes	at 1 °C	up to 10 days
Brussels sprouts	at 1 °C	up to 20 days
Asparagus	at 1 °C	up to 18 days
Spinach	at 1 °C	up to 13 days
Savoy cabbage	at 1 °C	up to 20 days
Fruit		
Apricots	at 1 °C	up to 13 days
Apples	at 1 °C	up to 80 days
Pears	at 1 °C	up to 55 days
Blackberries	at 1 °C	up to 3 days
Dates	at 1 °C	up to 180 days
Strawberries	at 1 °C	up to 7 days
Figs	at 1 °C	up to 7 days
Blueberries	at 1 °C	up to 9 days
Raspberries	at 1 °C	up to 3 days
Red currants	at 1 °C	up to 7 days
Cherries, sweet	at 1 °C	up to 14 days
Kiwi	at 1 °C	up to 80 days
Peaches	at 1 °C	up to 13 days
Plums	at 1 °C	up to 20 days
Cranberries	at 1 °C	up to 60 days
Rhubarb	at 1 °C	up to 13 days
Gooseberries	at 1 °C	up to 13 days
Grapes	at 1 °C	up to 29 days

4.2.3 Freezer compartment*

Guidelines for the shelf-lives of various foods		
Ice cream	at -18 °C	2 to 6 months
Cold cuts, ham	at -18 °C	2 to 3 months

Guidelines for the shelf-lives of various foods		
Bread, baked products	at -18 °C	2 to 6 months
Game, pork	at -18 °C	6 to 9 months
Fish, fatty	at -18 °C	2 to 6 months
Fish, lean	at -18 °C	6 to 8 months
Cheese	at -18 °C	2 to 6 months
Poultry, beef	at -18 °C	6 to 12 months
Vegetables, fruit	at -18 °C	6 to 12 months

5 Energy saving

- Always ensure good ventilation. Do not obstruct ventilation openings or grilles.
- Never block air slits in the fan.
- Do not install the appliance in direct sunlight or next to a stove, heater or similar heat source.
- Energy consumption depends on installation conditions such as the ambient temperature (see 1.4 Range of appliance use) . A warmer ambient temperature can increase the energy consumption.
- Avoid opening the appliance door for any longer than necessary
- The lower the temperature is set the higher the energy consumption.
- Sort your food items: home.liebherr.com/food.
- All food stored in the appliance should be well wrapped and covered. This prevents frost buildup.
- Only take food out for as long as necessary so that it does not get too warm.
- Insertion of warm foods: first let the food cool down to room temperature.
- Defrost frozen food in the fridge*
- If there is a thick layer of frost in the appliance Defrost the appliance.*
- For longer periods of absence, use HolidayMode (see HolidayMode) .

6 Use

6.1 Controls and displays

The display provides a quick overview of the temperature setting and the status of functions and settings. You can control the functions and settings either by deactivating/activating them or by selecting a value.

6.1.1 Status display

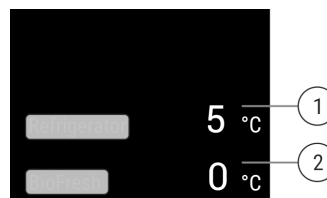

Fig. 5

(1) Fridge compartment temperature display

(2) Temperature display BioFresh

The Status display shows the set temperatures and is the home display. From there, you can navigate to the options and settings.

6.1.2 Navigation

Navigate in the menu to access the individual functions. An audible signal sounds after confirming a function or setting. If no selection is made after 10 seconds the display switches to the Status display.

The appliance is operated by swiping and confirming in the display:



Fig. 6

Back:

- Confirm your selection in the submenu. The display returns to the menu.





- Select . The display returns to the function/setting.

Back to Status display:

- Close and open the door.
- Wait 10 seconds. The display changes to the Status display.

6.1.3 Display symbols



The display symbols provide information about the current appliance status.



Symbol	Appliance status
	Standby The appliance or temperature zone is turned off.
	Flashing number Appliance is working. Temperature flashes until the set temperature is reached.
	
	Flashing symbol Appliance is working. Setting is made.
	

6.2 Operating logic

6.2.1 Activating/deactivating settings

You can activate/deactivate the following functions:

Symbol	Function
	SuperCool ^x
	PartyMode ^x

Symbol	Function
	HolidayMode
	EnergySaver
	HydroBreeze*

^x When function is on, the appliance works harder. This means appliance noise when operating may be louder for a short while, and more energy will be consumed.

- ▶ Swipe left in the display until the function appears.
- ▶ Confirm selected function with a short tap.
- ▷ You hear the confirmation tone.
- ▷ Status appears in the menu.
- ▷ Function is on/off.

6.2.2 Selecting function value

With the following functions you can set a value in the submenu:

Symbol	Function
	Setting the temperature
	Switch the appliance on/off







- ▶ Swipe left in the display until the function appears.
- ▶ Confirm selected function with a short tap.
- ▶ Select the setting value by swiping the display.

Setting the temperature

- ▶ Confirm selected value with a short tap.
- ▷ You hear the confirmation tone.
- ▷ The display changes to blue when it is activated.
- ▷ Display switches back to the menu.

6.2.3 Activating/deactivating settings

You can activate/deactivate the following settings:

Symbol	Setting
	WiFi ¹
	Entry lock ²
	SabbathMode ²
	Cleaning Mode ²
	Reminders ¹
	Reset ²
	Switch off ²

- ▶ Swipe left in the display until Settings  appears.
- ▶ Confirm settings by tapping.
- ▶ Swipe until you can see the setting you want.

¹ Activate setting (short press)

- ▶ Tap briefly to confirm.
- ▷ You hear the confirmation tone.

Use



- ▷ Status appears in the menu.
- ▷ Setting is activated / deactivated.

² Activate setting (long press)

- ▶ Press selection for 3 seconds to confirm.
- ▷ You hear the confirmation tone.
- ▷ Status appears in the menu.
- ▷ Display changes.

6.2.4 Selecting the setting value





With the following settings you can set a value in the submenu:



Symbol	Settings
	Brightness
	Door alarm
	Language

- ▶ Swipe the display to the left until the settings  are displayed.
- ▶ Confirm the settings by tapping.
- ▶ Swipe until you can see the setting you want.
- ▶ Tap briefly to confirm.
- ▶ Select the desired setting value by swiping the display.
- ▶ Tap briefly to confirm.
- ▷ You hear the confirmation tone.
- ▷ Status appears briefly in the submenu.
- ▷ Display switches back to the menu.

6.2.5 Calling up the customer menu

The customer menu provides the following settings:

Symbol	Function
	BioFresh B-Value ¹
	C-Value ^{1*}
	D-Value ¹
	Software

- ▶ Swipe left in the display until the settings  appear.
- ▶ Tap settings.
- ▷ The submenu appears.
- ▶ Swipe left in the display until the appliance information  appears.
- ▶ Press for 3 seconds.
- ▷ The input menu for a numerical code appears.
- ▶ Enter the numerical code 151.
- ▷ The customer menu appears.
- ▶ Swipe left in the display until the desired setting appears.

¹ Select the setting value

- ▶ Tap briefly to confirm.
- ▷ You hear the confirmation tone.
- ▷ Status appears briefly in the display.
- ▷ The display switches back to the menu.

² Activate setting

- ▶ To confirm, press the display for 3 seconds.

- ▷ You hear the confirmation tone.
- ▷ Status appears in the display.
- ▷ The symbol flashes as long as the appliance is working.

6.3 Functions

Turn off appliance

This setting turns off the whole appliance.

Switch off whole appliance

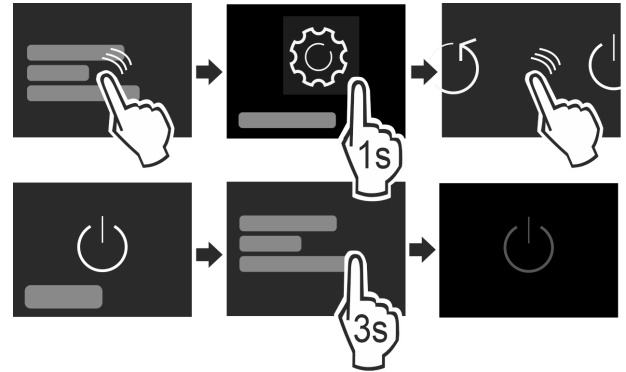

Fig. 7

- ▶ Activating/deactivating (see 6.2 Operating logic).
- ▷ Off: Display turns black.

WiFi

Use this function to connect your appliance to the WiFi. You can then operate it via the SmartDevice app on a mobile device. You can also use this function to disconnect or reset the WiFi connection. To connect your appliance to the WiFi, you need the SmartDeviceBox. For more information about the SmartDeviceBox and how to use the SmartDevice app: (see 1.3 SmartDevice)

Note

You cannot use the SmartDeviceBox in the following countries: Russia, Belarus, Kazakhstan. The SmartDevice function is not available.

Establishing a WiFi connection

Make sure that the following requirements are fulfilled:

- You have a SmartDeviceBox and it is switched on. (see 1.3 SmartDevice) *
- You have installed the SmartDevice app (see apps.home.liebherr.com).

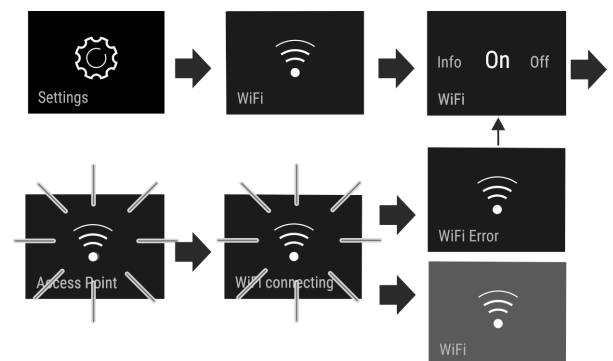

Fig. 8

- ▶ Activate the setting. (see 6.2 Operating logic)
- ▷ Connection is established: Connecting appears. The symbol flashes.

- ▷ Connection is established: WiFi appears, the display turns blue.
- ▷ Connection failed: WiFi Error appears.

Disconnecting from the WiFi

- ▶ Deactivate the setting. (see 6.2 Operating logic)

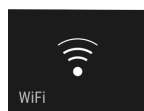
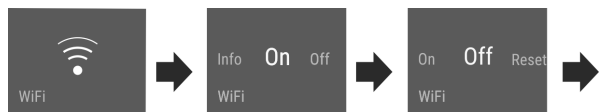



Fig. 9

- ▷ There is no connection: Symbol  is permanently visible.

Resetting the WiFi connection

- ▶ Reset settings. (see 6.2 Operating logic)

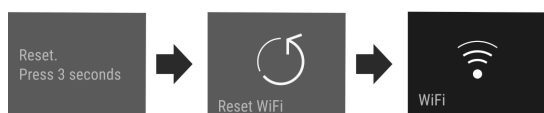
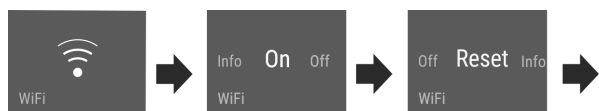



Fig. 10

- ▷ The connection and other settings are reset to the factory settings.

5 °C Temperature

The temperature depends on the following factors:

- the number of times the door is opened
- The duration the door is opened
- the room temperature of the installation location
- the type, temperature and amount of food

Temperature zone	Recommended setting
 Fridge	5 °C
 BioFresh	(see BioFresh B-Value)

Setting the temperature

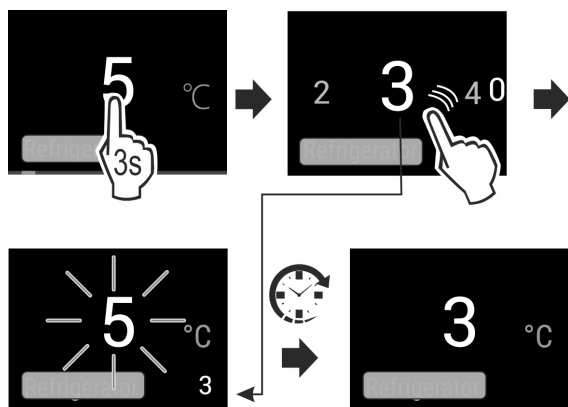

Fig. 11

- ▶ Set the value. (see 6.2 Operating logic) .
- ▷ The set temperature is shown on the bottom right of the display.

Setting the temperature in the BioFresh

You can set the temperature using the **BioFresh B-Value** in the customer menu. (see BioFresh B-Value)

B5 BioFresh B-Value

In the delivery condition of the appliance, the value is set to **B5**. The status indicator on the display shows the appropriate target temperature in the BioFresh.

You can change this value slightly if a higher or lower ambient temperature makes it necessary. When setting the value, note:

Value	Description
B1	Lowest temperature
B1-B4	The temperature can drop to below 0 °C, so food can freeze easily.
B5	Default temperature
B9	Highest temperature

BioFresh B-Value

Choosing the setting

- ▶ Make your settings in the Customer menu (see 6.2 Operating logic) .

C5 C-Value*

The *C-Value* can be used to set the temperature of the 4*-compartment slightly warmer or colder.*

The *C-Value* is set to **C5** by default.*

The 4*-compartment becomes colder with all values less than **C5**. The 4*-compartment becomes warmer with all values greater than **C5**.*

Selecting the setting value*

- ▶ Set value in customer menu (see 6.2 Operating logic) .

D1 D-Value

The *D-Value* is preset for your appliance and may not be changed.

SuperCool

Select this function for the maximum cooling setting, to reach lower cooling temperatures.

This function is relevant to the fridge section Fig. 1 (A)

You can also reach lower temperatures in the 4-star freezer.*

Use:

- Cool large amounts of food quickly.
- Freeze food.*

Activating/deactivating settings

- ▶ Using the 4-star freezer: activate the function 3 hours beforehand.*
- ▶ Using the fridge section: activate the function when you add the goods.
- ▶ Activating/deactivating (see 6.2 Operating logic) .

Use

-or-

▶ Activate/deactivate using the SmartDevice app.*

The function automatically turns off. The appliance goes back to normal mode. The temperature adjusts itself to the set level.



PartyMode

This option offers an assortment of special functions and settings that are useful if you are having a party.

The following functions are activated:

- SuperCool
- InfinitySpring*

You can set any functions you like. Your changes are lost when the option is switched off.

Activating/deactivating settings

- ▶ Activating/deactivating (see 6.2 Operating logic) .
 - ▷ On: All functions are activated at the same time.
 - ▷ Deactivated: Previously set temperatures are restored.
- The function is automatically switched off after 24 hours.



HolidayMode

This function minimizes the energy consumption during an extended absence. The temperature of the refrigerator compartment is set to 15 °C and this is displayed on the status screen when the temperature has been reached.

Use:

- Save energy if you plan to be away for a while.
- Avoid coming home to bad smells and mold.

Activating/deactivating settings

- ▶ Empty everything from the fridge section.
- ▶ Activating/deactivating (see 6.2 Operating logic) .
- ▷ On: Fridge temperature is raised.
- ▷ Off: The previously set temperature is restored.



SabbathMode

With this function you can activate or deactivate the SabbathMode. If you activate this function, some electronic functions will be switched off. This allows your device to meet religious requirements on Jewish holidays such as the Sabbath and comply with STAR-K Kosher certification.

Appliance status with active SabbathMode
The status display continuously shows SabbathMode.
All functions in the display except the Deactivate SabbathMode function are locked.
Active functions remain active.
The display stays lit when you close the door.
The interior lighting is switched off.
Reminders are disabled. The set time intervals are paused.
Reminders and warnings are not displayed.
There is no door alarm.
There is no temperature alarm.
The InfinitySpring is out of operation.*
The defrost cycle only works for the specified time without taking account of appliance use.

Appliance status with active SabbathMode

After a power failure, the appliance returns to SabbathMode.

Appliance status

Note

This appliance has certification from the "Institute for Science and Halacha". (www.machonhalacha.co.il)

You can find a list of STAR-K-certified appliances at www.star-k.org/appliances.

Activating SabbathMode



WARNING

Danger of poisoning from spoiled food!

If you have SabbathMode activated and a power failure occurs, no message appears in the status display about the power failure. Once the power is restored, the appliance continues to operate in SabbathMode. The power failure may mean that food spoils and the consumption of this food could lead to food poisoning.

After a power failure:

- ▶ Do not consume food that has been frozen and thawed.

- ▶ Call up the settings menu. (see 6.2 Operating logic)
- ▶ Swipe left or right until the corresponding function is displayed.

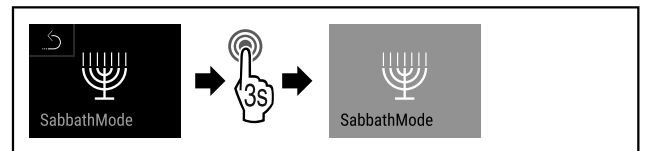

Fig. 12

- ▶ Complete the steps (see Fig. 1562) .
- ▷ SabbathMode is activated.
- ▷ Status display continuously shows SabbathMode.

Deactivating SabbathMode

- ▶ Call up the settings menu. (see 6.2 Operating logic)
- ▶ Swipe left or right until the corresponding function is displayed.

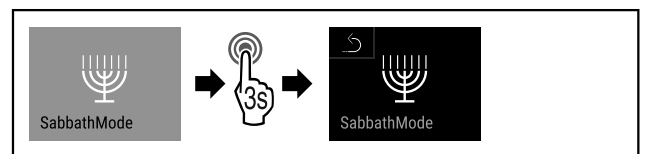

Fig. 13

- ▶ Complete the steps (see Fig. 1563) .
- ▷ SabbathMode is deactivated.



EnergySaver

This function activates or deactivates the energy-saving mode. When you activate this function, the energy consumption decreases and the temperature increases by 2 °C in the appliance. The food remains fresh, but the shelf life is shortened.

Temperature zone	Recommended setting	Temperature when EnergySaver activated	when activated
5 °C Fridge compartment	5 °C	7 °C	

Temperatures

Activating EnergySaver

- ▶ Swipe left or right until corresponding function is displayed.

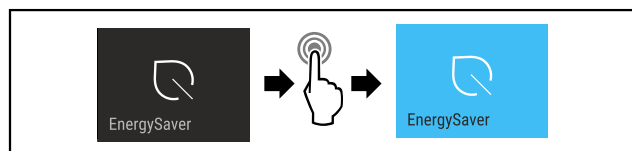

Fig. 14

- ▶ Complete the steps (see Fig. 1564).
- ▷ Energy-saving mode is activated.

Deactivating EnergySaver

- ▶ Swipe left or right until corresponding function is displayed.

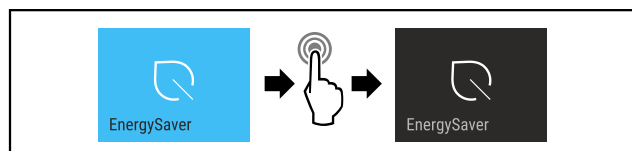

Fig. 15

- ▶ Complete the steps (see Fig. 1565).
- ▷ Energy-saving mode is deactivated.

HydroBreeze*

HydroBreeze creates a fine mist in the drawer every 90 minutes for 4 seconds when the door is closed. This function is also activated when you open the door. The function is not activated when the appliance is delivered.

Use:

- For storing unpackaged salad, vegetables and fruit with high natural moisture levels.

The following settings are possible:

- 1: Function duration when the door is opened 4 s
- 2: Function duration when the door is opened 6 s
- 3: Function duration when the door is opened 8 s
- Off: HydroBreeze is deactivated.

Activating/deactivating settings

- ▶ Activating/deactivating (see 6.2 Operating logic).
- or-
- ▶ Activating/deactivating in the Liebherr SmartDevice-App.*

CleaningMode

This setting makes it easy to clean the appliance.

This setting is relevant to the fridge section Fig. 1 (A).

Use:

- Clean the fridge section manually.
- Clean the InfinitySpring.*

What happens with the appliance when this setting is on:

- The display shows CleaningMode permanently.
- The refrigerator compartment is switched off.
- The internal light is on.
- Reminders and warnings are not shown. There is no acoustic signal.
- InfinitySpring is out of use.*

Activating/deactivating settings

- ▶ Activate/deactivate setting (see 6.2 Operating logic).
- ▷ On: Fridge compartment is switched off. Light stays on.
- ▷ Off: preset temperature is restored.

The setting is automatically deactivated after 60 minutes. Then the appliance continues operation in normal mode.

Display brightness

With this setting, you can choose a brightness level for the display.

You can set the following brightness levels:

- 40%
- 60%
- 80%
- 100%

Choosing the setting

- ▶ Set the level (see 6.2 Operating logic).

Door alarm

Set the time before the door alarm (see Close the door) sounds.

Options are as follows:

- 1 min
- 2 min
- 3 min
- Off

Choosing the setting

- ▶ Set the level (see 6.4 Error messages).

Entry lock

This setting avoids accidental operation of the appliance, e.g. by children.

Use:

- Avoid unintentional changing of settings and functions.
- Avoid unintentional switching off of the appliance.
- Avoid unintentional temperature adjustments.

Activating/deactivating settings

- ▶ Activating/deactivating (see 6.2 Operating logic).

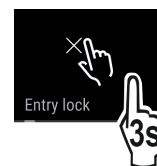

Language

This setting lets you choose the language of the display.

Use

Choose from the following languages:

- German
- English
- French
- Spanish
- Italian
- Dutch
- Czech
- Polish
- Portuguese
- Russian
- Chinese

Activating/deactivating settings

▶ Activating/deactivating (see 6.2 Operating logic) .



Info

This setting allows the appliance information to be read out as well as access to the customer menu.

It provides the following information:

- Model name
- Index
- Serial number
- Service number

View appliance data

- ▶ Swipe in the display until Settings  appears.
- ▶ Confirm the display.
- ▶ Swipe in the display until About appears.
- ▶ Read the appliance data.



Reminder

Reminders are displayed acoustically by a beep and visually by a symbol in the display. The signal gets louder until the alert stops.



Replace water filter*

This message appears when the water filter needs replacing.

- ▶ Replace the water filter every 6 months.
- ▶ Confirm the message with OK.
- ▷ The service interval resets.
- ▷ The water filter guarantees the best water quality.



Replace the FreshAir active carbon filter

This message appears when the air filter needs replacing.

- ▶ Replace the air filter every six months.
- ▶ Confirm the message with OK.
- ▷ The service interval resets.
- ▷ The air filter guarantees the air quality in the fridge.

Activate setting

▶ Activating/deactivating (see 6.2 Operating logic) .



Reset

This function resets all settings to the factory settings. All settings that you have made thus far will be reset to their original values.

Activate the setting

▶ Activating (see 6.2 Operating logic) .

6.4 Error messages

Error messages appear in the display. There are two categories of error message:

Category	Meaning
Message	Reminder of general procedures. You can carry out these procedures to eliminate the message.
Warning	Appears when there are malfunctions. A signal sounds in addition to the display. The signal becomes louder until you acknowledge by tapping the display. You can eliminate simple defects yourself. For more serious defects, you must contact customer service.

6.4.1 Warnings



Close the door

This message appears if the door is open too long.

You can set the time before this message appears .

▶ Stop alarm: Confirm the message.

-or-

▶ Close the door.



Error

This message appears when there is a fault with the appliance. An appliance component has an error.

- ▶ Open the door.
- ▶ Take note of the error code.
- ▶ Confirm the message.
- ▷ The signal tone stops.
- ▷ The status display appears.
- ▶ Close the door.
- ▶ Contact customer service. (see 9.4 Customer service)

6.4.2 Message



Water tank*

This message appears if there is not enough water in the water tank.

- ▶ Fill the water tank.
- ▷ The IceMaker produces ice cubes.
- ▶ When the water tank is full and the following message appears: Check if the float is stuck.
- ▶ If necessary, drain the water and release the float with a thin object such as a cotton bud.
- ▶ When the water tank is full and the following message appears: Contact customer service. (see 9.4 Customer service)

6.4.3 DemoMode

If "D" appears in the display, demo mode is on. This feature is designed for retailers. The cooling features are disabled.

Switching off DemoMode

When you see a time counting down:

- ▶ Confirm within the countdown.
- ▷ DemoMode is off.

If there is no countdown:

- ▶ Disconnect the power plug.
- ▶ Reconnect the power plug.
- ▷ DemoMode is off.

7 Equipment

7.1 4-star freezer*

7.1.1 Open/close freezer

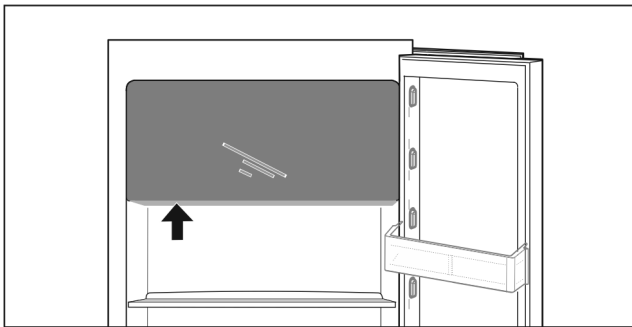
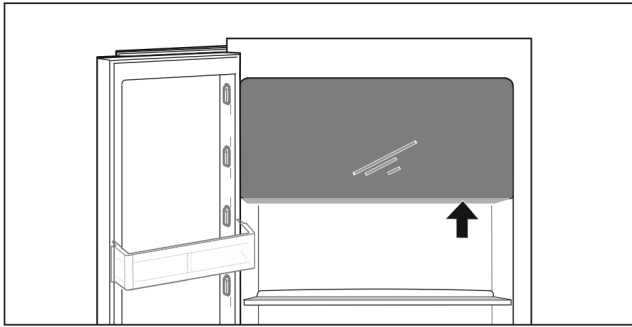

Fig. 16

Open freezer:

- ▶ Reach into the handle area from below.
- ▶ Push the handle plate and pull the door forward at the same time.

Close freezer:

- ▶ Close the door and press from the front at the same time.
- ▷ Door is engaged.

7.2 Door racks

7.2.1 Moving/removing door racks

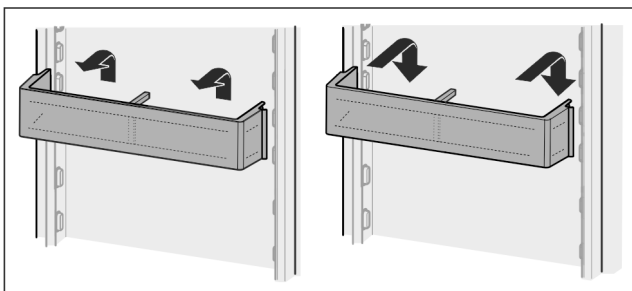

Fig. 17

- ▶ Slide racks up.
- ▶ Pull to the front.
- ▶ Re-insert in reverse order.

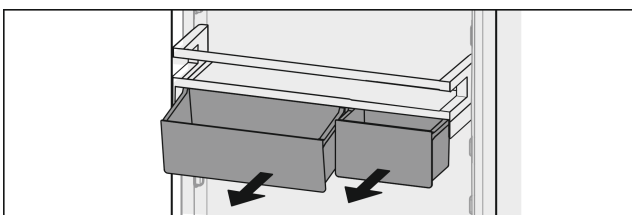

Fig. 18 *

You can use just one or both VarioBoxes. To store oversized bottles, suspend just one box over the bottle rack.*

Move the VarioBox shelf:*

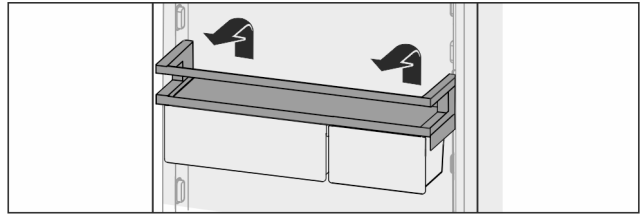

Fig. 19 *

- ▶ Pull up and out.*
- ▶ Replace at any position.*
- ▷ In front of 4-star freezer: Optimum air flow in the appliance is no longer guaranteed. Condensate may form on the freezer compartment.*

Note

Liebherr recommends the following:*

- ▶ Put the VarioBox shelf in its default position, anywhere below the 4-star freezer. This will provide the best air flow in the fridge section.*

Moving the VarioBoxes:*

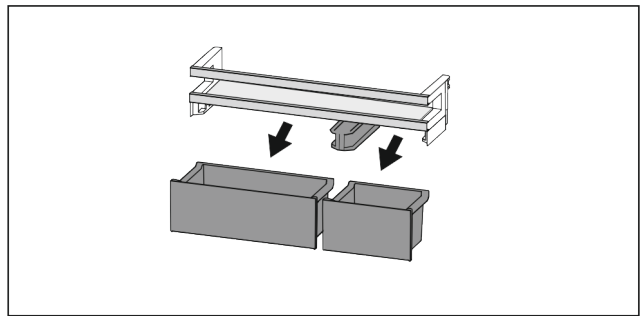

Fig. 20 *

- ▶ If the door rack is removed:*
- ▶ Remove boxes.*

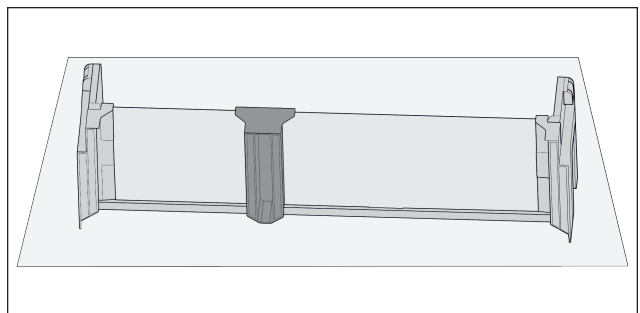

Fig. 21 *

- ▶ Place the shelf on the table.*

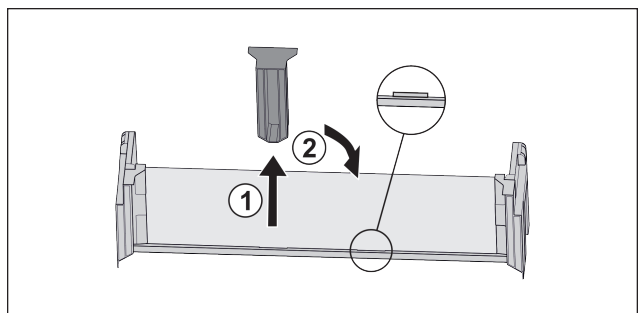

Fig. 22 *

- ▶ Pull off the middle holder Fig. 22 (1).*
- ▶ Insert the middle holder in the second position Fig. 22 (2).*

Equipment

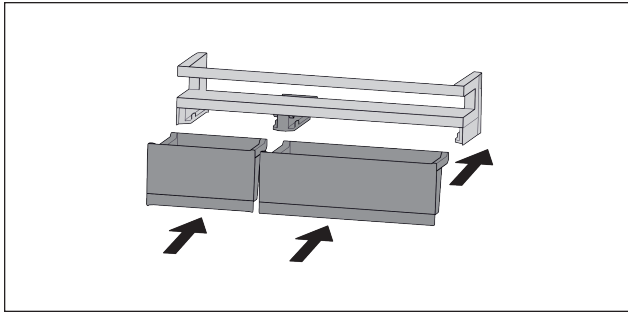

Fig. 23 *

- ▶ Replacing boxes.*

7.2.2 To dismantle door racks

The door racks can be disassembled for cleaning.

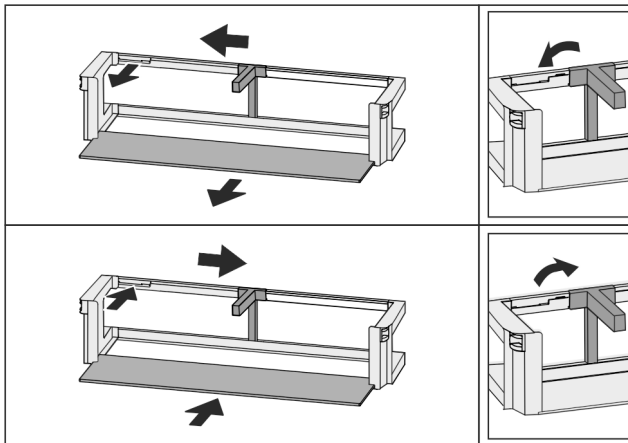

Fig. 24

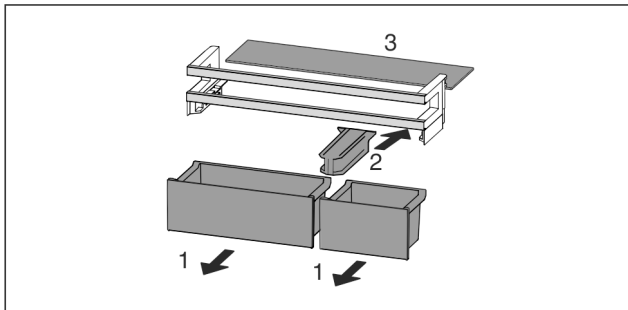

Fig. 25 *

- ▶ Disassemble the door racks.

7.3 Shelves

7.3.1 Moving/removing shelves

Extension stops secure the shelves against being accidentally pulled out

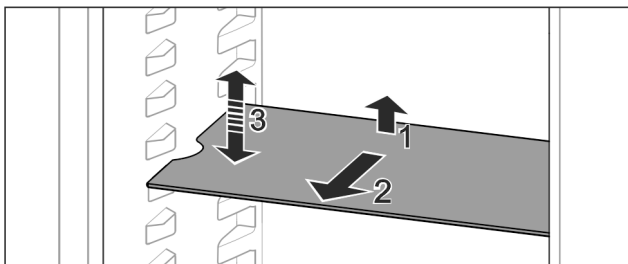

Fig. 26

- ▶ Lift the shelf and pull to the front.
- ▷ Side recess to shelf position.

- ▶ Reposition the shelf: Lift up or lower to the desired height and insert.

-or-

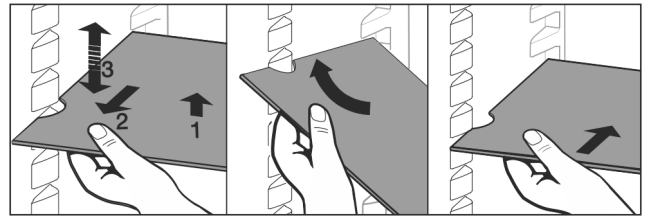

Fig. 27

- ▶ Take out the shelf completely: Pull out to the front.
- ▶ Easier removal: Set the shelf at an angle.
- ▶ Reinsert the shelf: Push it in to its stop limit.
- ▷ Pull-out stoppers are pointing down.
- ▷ Pull-out stoppers are behind the front shelf.

7.4 Split shelf

7.4.1 Using the split shelf

Extension stops secure the shelves against being accidentally pulled out

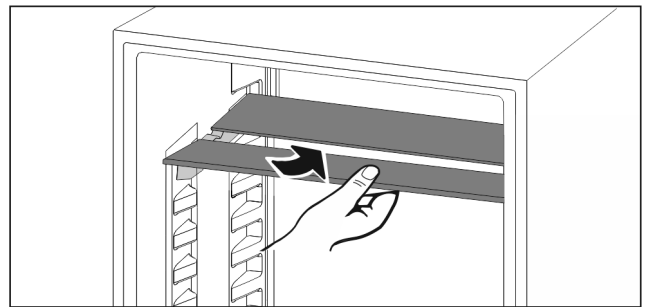

Fig. 28

- ▶ Push the split shelf underneath as in the illustration

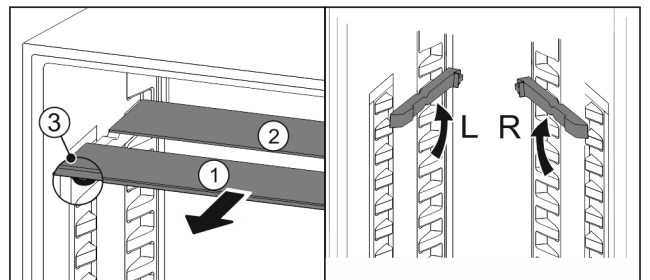

Fig. 29

Adjusting heights:

- ▶ Pull the glass panels out Fig. 29 (1) from the front, one at a time.
- ▶ Pull the support rails out of their retainers and snap into place at the height you want them.
- ▶ Slide in the glass panels one at a time.
- ▷ Flat pull-out stoppers at the front, right behind the support rail.
- ▷ Taller pull-out stoppers at the back.

Using both shelves:

- ▶ Hold the bottom glass panel with one hand and pull it to the front.
 - ▷ The glass panel Fig. 29 (1) with the trim strip is at the front.
 - ▷ The stops Fig. 29 (3) point downward.
- Appliances with freezer:*
- ▶ Do not place shelf rails and split shelves in front of the fan.*

7.5 VarioSafe*

The VarioSafe provides space for small food, packs, tubes, and jars.

7.5.1 Using the VarioSafe

You can remove the drawer and slide it back in at two different heights. This is to accommodate taller small items in the drawer.

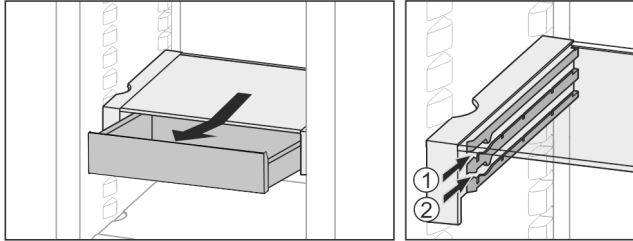

Fig. 30

- ▶ Remove the drawer.
- ▶ Slide in at any height Fig. 30 (1) or Fig. 30 (2).

7.5.2 Moving the VarioSafe

You can shift the height of the entire VarioSafe unit.

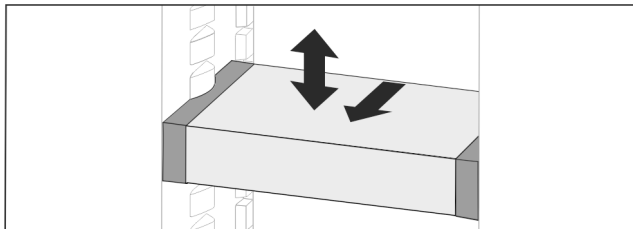

Fig. 31

- ▶ Pull to the front.
- ▷ Side recess to shelf position.
- ▶ Raise or lower to any height.
- ▶ Slide to the rear.

7.5.3 Removing the VarioSafe completely

You can remove the entire VarioSafe unit.

- ▶ Pull to the front.
- ▷ Side recess to shelf position.

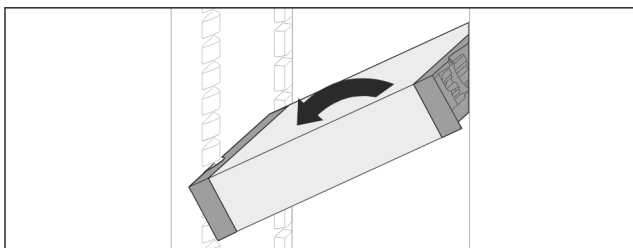

Fig. 32

- ▶ Tilt and pull to the front.

7.5.4 Disassembling the VarioSafe

The VarioSafe can be dismantled for cleaning.

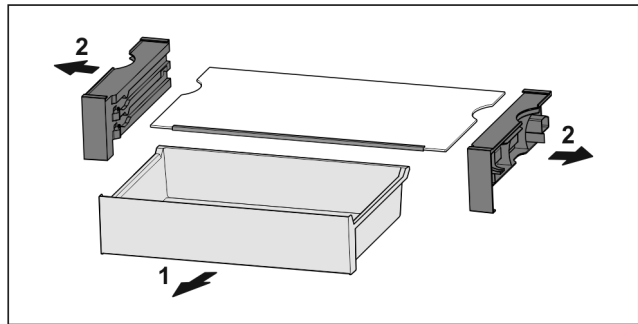

Fig. 33

- ▶ Dismantling the VarioSafe.

7.6 InfinitySpring*

The built-in water dispenser provides convenient drinking water. The water temperature depends on the temperature in the fridge.

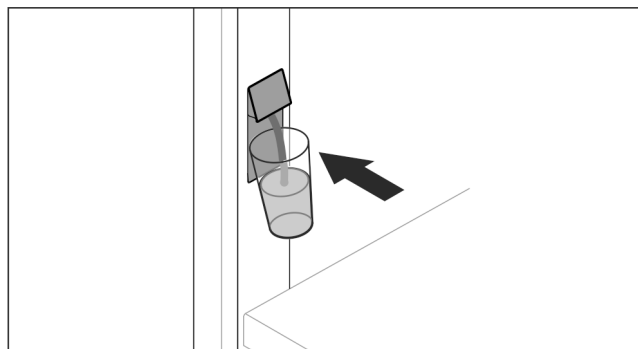

Fig. 34

- ▶ Push the glass against the button pushbutton of the dispenser.
- ▷ The outlet unit moves out: water pours into the glass.
- ▶ Avoid splashes: Remove the glass slowly.
- ▶ If dispensing larger quantities of water: If the water flow stops, remove the water tank and push your container against the button push button of the dispenser again.

7.7 Space for baking tray

There is space for a baking tray Fig. 1 (9) above the drawers.

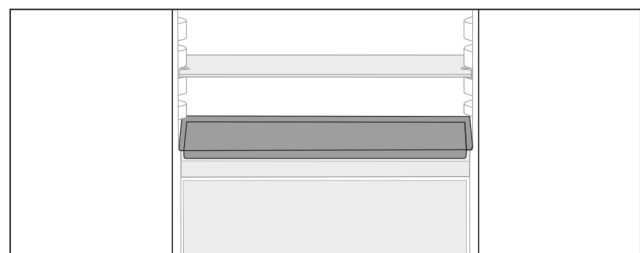

Fig. 35

Make sure that the following requirements are fulfilled

- Max. baking tray dimensions are adhered to (see 9.1 Technical specifications).
- Baking tray has cooled to room temperature.
- The bottom door stopper is set at least one position up.

When door 90° is open:

- ▶ Slide the baking tray onto the lower side runs.

-or-

- ▶ If baking tray is uneven: Use the supplied support rails.

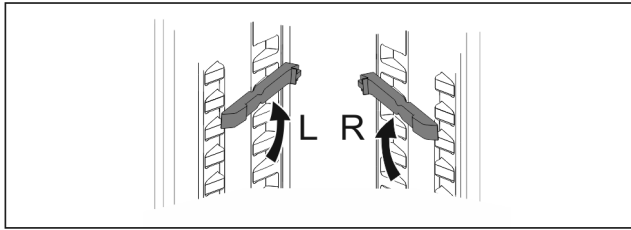

Fig. 36

- ▶ Snap support rails into the lowest runs. When door 90° is open:
- ▶ Slide the baking tray in on the support rails.

7.8 Variable bottle shelf

7.8.1 Using the bottle shelf

Use the variable bottle shelf or the glass panel placed on the fridge floor.

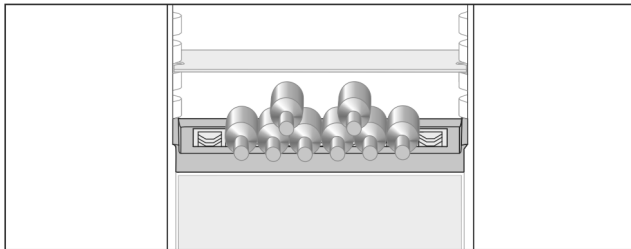

Fig. 37

- ▶ Remove the glass shelf and store separately.
- ▶ Place the bottles with the base pointing backwards facing the rear wall

Note

If the bottles protrude over the front of the bottle shelf:

- ▶ Move the bottom door rack higher up.

7.8.2 Removing the bottle shelf

You can remove the bottle shelf for cleaning.

- ▶ Remove the glass panel above the bottle shelf.

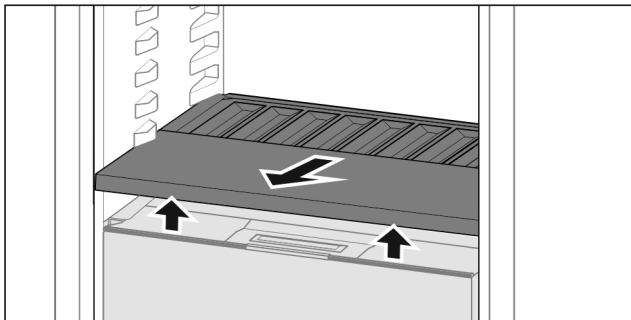

Fig. 38

- ▶ Lift the bottle shelf at the front and pull out.

Note

Liebherr recommends the following:

Do not place any goods on the drawer cover below.

7.8.3 Inserting the bottle shelf

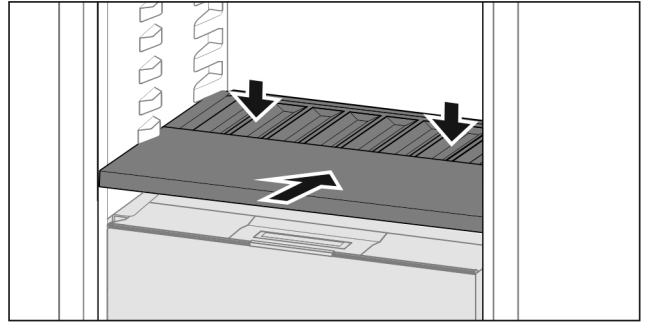

Fig. 39

- ▶ Slide in the bottle shelf until it engages and push down.
- ▷ The lugs at the back of the bottle shelf are connected automatically.
- ▷ LED lights up.

7.9 Drawers

You can remove the drawers for cleaning.

The way to remove/insert the drawers varies depending on the pull-out system. Your appliance can contain a variety of pull-out systems.

Note

Insufficient ventilation results in an increase in energy consumption and reduction of the refrigerating performance.

- ▶ Never obstruct the vents on the interior rear wall!

7.9.1 Drawer on telescopic rails

The drawer runs on full-extension rails (telescopic rails). There are full-extension telescopic rails and telescopic rails with partial pull-out. Drawers which are full extension can be pulled out fully from the appliance. Drawers with partial pull-out cannot be pulled out fully from the appliance. The system in your appliance depends on the type of appliance.

Full extension*

If you have full-extension rails, there is a clamp located at the back on the left and right of the rail.

Removing drawer

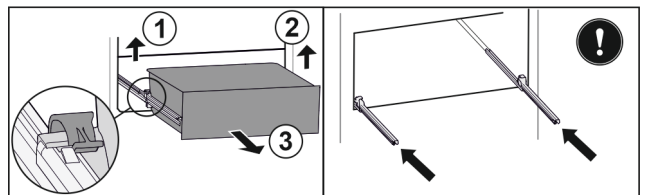

Fig. 40

- ▶ Pull out drawer as far as it will go.
- ▶ Lift left clamp and simultaneously pull drawer forwards on the left. Fig. 40 (1)
- ▶ Lift right clamp and simultaneously pull drawer forwards on the right. Fig. 40 (2)
- ▶ Remove drawer to the front. Fig. 40 (3)
- ▶ Slide rails in.

Inserting drawer

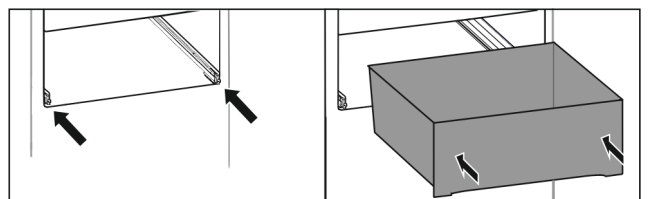

Fig. 41

- ▶ Slide rails in.
- ▶ Place drawer on rails.
- ▶ Slide in drawer to the back.
- ▷ Drawer latches in audibly at the back.

Partial pull-out fridge compartment*

Removing drawer

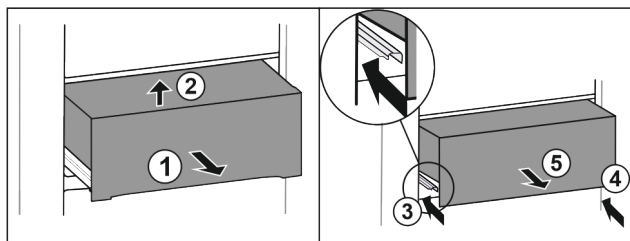

Fig. 42

- ▶ Pull out the drawer halfway. Fig. 42 (1)
- ▶ Lift drawer at the front. Fig. 42 (2)
- ▶ Slide in left rail. Fig. 42 (3)
- ▶ Slide in right rail. Fig. 42 (4)
- ▶ Remove drawer to the front. Fig. 42 (5)

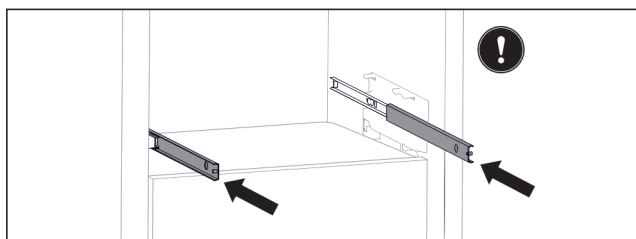

Fig. 43

If the rails are not yet fully pushed in after removing the drawer:

- ▶ Push the rails in completely.

Inserting drawer

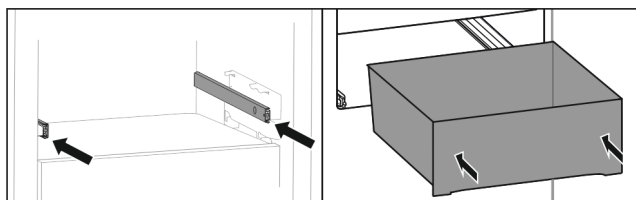

Fig. 44

- ▶ Slide rails in.
- ▶ Place drawer on rails.
- ▶ Slide in drawer to the back.

7.10 Fruit & Vegetable-Safe cover

The compartment lid can be removed for cleaning.

7.10.1 Removing the compartment lid

Make sure that the following requirements are fulfilled

- ☐ Bottle shelf is removed (see 7.8 Variable bottle shelf).

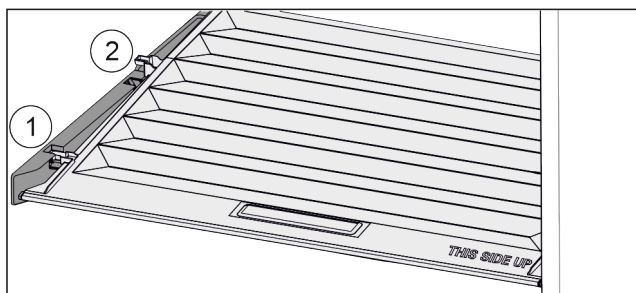

Fig. 45

If the drawers are removed:

- ▶ Pull the lid up at the front in the retaining parts to the opening Fig. 45 (1).
- ▶ Lift from the back and pull it up and out Fig. 45 (2).

7.10.2 Inserting the compartment lid

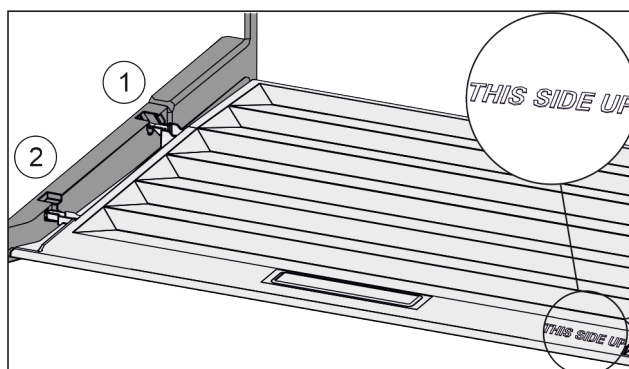

Fig. 46

If the text THIS SIDE UP is on top:

- ▶ Insert the lip of the cover over the opening of the rear bracket Fig. 46 (1) and click into place Fig. 46 (2).
- ▶ Position the cover where you want it (see 7.11 Humidity control).

7.11 Humidity control

You can regulate the moisture in the drawer yourself by adjusting the compartment cover.

The compartment cover is on the drawer itself and can be covered with shelves or additional drawers.

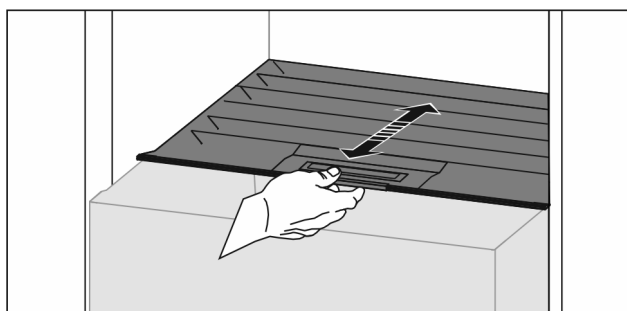

Fig. 47

Low air humidity

- ▶ Open the drawer.
- ▶ Pull the drawer cover to the front.
- ▷ If the drawer is closed: Gap between lid and compartment.
- ▶ Switch off HydroBreeze.*
- ▷ Moisture levels lower in the Safe.

High air moisture:

- ▶ Open the drawer.
- ▶ Slide the compartment cover to the back.
- ▷ If the drawer is closed: The cover seals the compartment.
- ▶ Activate the HydroBreeze.*
- ▷ Moisture levels rise in the Safe.
- If there is too much moisture in the compartment:
- ▶ Choose a "low moisture setting".
- or-
- ▶ Remove the moisture with a cloth.

Note

With the "low humidity" setting, the Fruit & Vegetable-Safe can also be used as a Meat & Dairy-Safe.

- ▶ Choose a "low moisture" setting.

Equipment

7.12 HydroBreeze*

HydroBreeze emits a mist over the refrigerated goods to provide moisture every time the door is opened.

The HydroBreeze and its water tank are located in the adjustable bottle shelf.

Make sure that the following requirements are fulfilled

- The water tank is clean (see 8.7.3 Cleaning the equipment) .
- The water tank is properly engaged.
- Moisture is set to "high moisture" (see 7.11 Humidity control) .
- HydroBreeze is on (see HydroBreeze*) .

7.12.1 Fill the water tank



WARNING

Contaminated water!
Poisoning.

- ▶ Fill with drinking water only.
- ▶ HydroBreeze is off: Empty the water tank.
- ▶ HydroBreeze is out of use for a prolonged period: Empty the water tank.

NOTICE

Sugary liquids!
Damage to the HydroBreeze.

- ▶ Fill with drinking water only.

Note

Use filtered, decarbonized water to provide the best-quality drinking water and keep the HydroBreeze working smoothly. This water quality can be achieved using a table water filter of the kind available in trade retail outlets.

- ▶ Fill the water tank with filtered, decarbonized drinking water.

The water tank is built into the adjustable bottle shelf (see 1.2 Overview of the appliance and its equipment) .

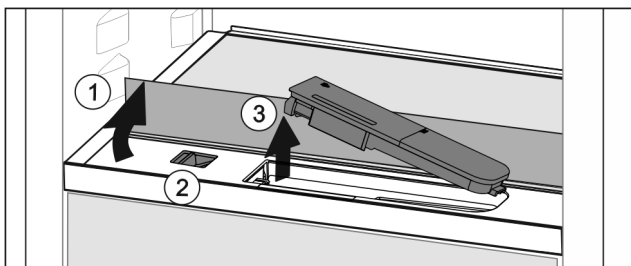

Fig. 48

- ▶ Press on the back-left corner of the front glass plate.
 - ▷ The glass panel folds upwards.
 - ▶ Lift the glass panel and fold to the back as far as it will go Fig. 48 (1).
 - ▷ The glass panel is upright.
 - ▶ Slide the slider Fig. 48 (2) to the left.
 - ▷ The water tank jumps out of its recess.
 - ▶ Remove the water tank Fig. 48 (3).
 - ▶ Cleaning the water tank (see 8.7.3 Cleaning the equipment) .
- Angular opening:
- ▶ Fill with drinking water up to the level mark.
 - ▶ Insert the water tank, bottom first, into the recess.
 - ▶ Slowly lower the front part and push the tank in.
 - ▷ Water tank is engaged.

7.12.2 Disassembling the water tank

You can disassemble the water tank for cleaning.

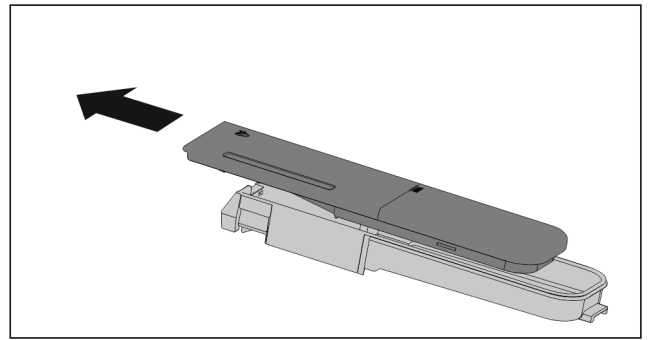

Fig. 49

- ▶ Disassemble the water tank.

7.13 Accessories

7.13.1 Butter dish

Opening/closing the butter dish

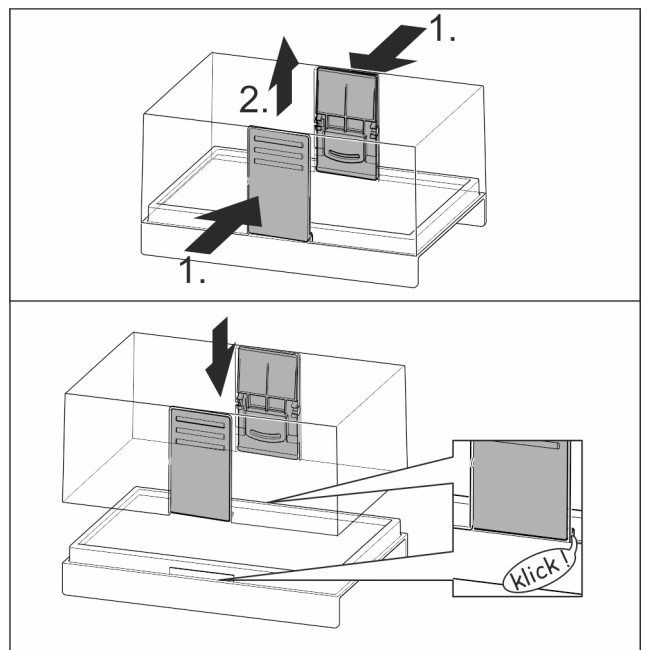

Fig. 50

Dismantling the butter dish

You can disassemble the butter dish for cleaning.

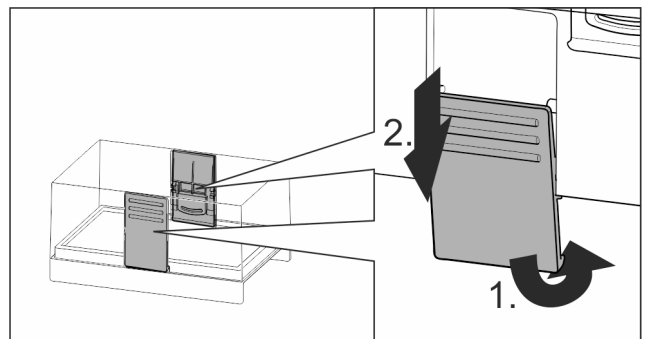

Fig. 51

- ▶ Disassemble the butter dish.

7.13.2 Egg rack

You can pull out and turn the egg rack. You can use both sides of the egg rack so you can label specifics like the purchase date.

Using the egg rack

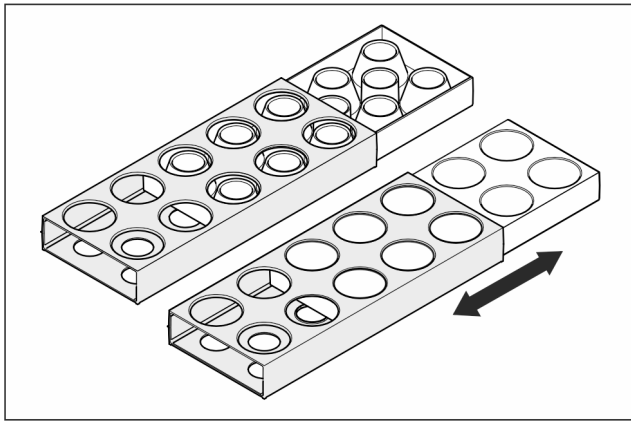

Fig. 52

- ▶ Top section: store hen eggs.
- ▶ Bottom section: store quail eggs.

7.13.3 Bottle rack

Using the bottle rack

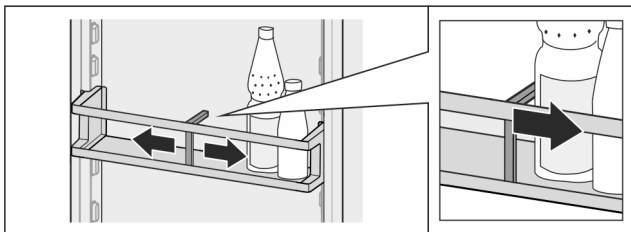

Fig. 53

- ▶ Slide the bottle rack at the edges.
- ▷ Stops bottles from tipping over.

Removing the bottle rack

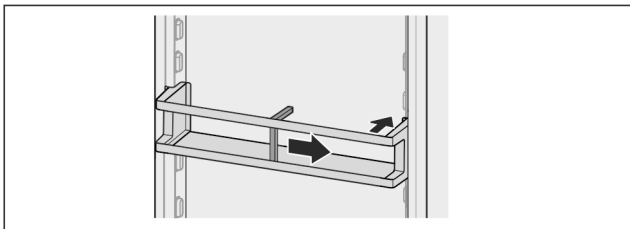

Fig. 54

- ▶ Slide the bottle rack all the way to the right edge.
- ▶ Remove to the back.

7.13.4 Ice cube tray with lid*

Using the ice cube tray

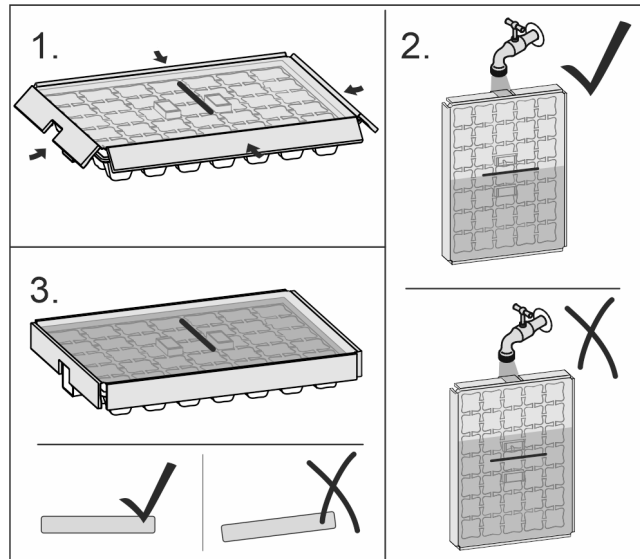

Fig. 55

When water is frozen:

- ▶ Hold the ice cube tray briefly under warm water.
- ▶ Remove the lid.
- ▶ Gently turn the ends of the ice cube tray in opposite directions.
- ▶ Release the ice cubes.

Dismantling the ice cube tray

You can dismantle the ice cube tray for cleaning.

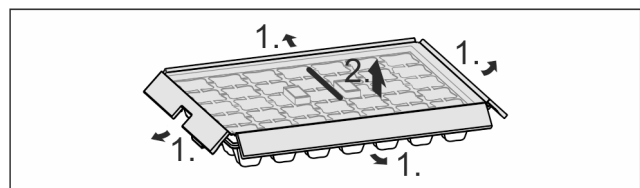

Fig. 56

- ▶ Disassemble the ice cube tray.

8 Maintenance

8.1 FreshAir carbon filter

The FreshAir carbon filter is located in the compartment above the fan.

It guarantees the best air quality.

- Change the carbon filter every 6 months.
When the reminder is set, a message on the display prompts you to change it.
- You can dispose of the carbon filter with the regular household waste.

Note

FreshAir activated charcoal filters can be purchased from the Liebherr-Hausgeräte store at home.liebherr.com/shop/de/deu/zubehor.html.

Maintenance

8.1.1 Removing the FreshAir carbon filter

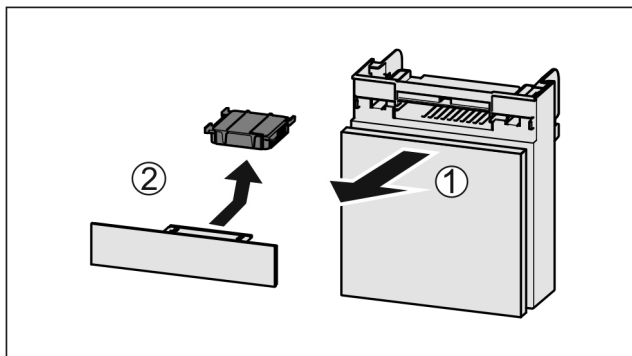

Fig. 57

- ▶ Pull out the compartment Fig. 57 (1).
- ▶ Remove the carbon filter Fig. 57 (2).

8.1.2 Inserting the FreshAir carbon filter

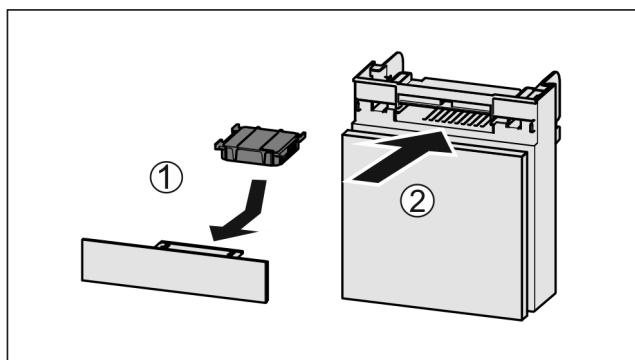

Fig. 58

- ▶ Insert the carbon filter as shown in the diagram Fig. 58 (1).
- ▷ The carbon filter clicks into place.
- ▷ If the carbon filter is pointing downwards:
 - ▶ Push the compartment in Fig. 58 (2).
 - ▷ The carbon filter is now ready for use.

8.2 Water tank*

The InfinitySpring water tank is located behind the lowest drawer.

8.2.1 Removing the water tank

- ▶ Turn off the water tap.
- ▶ Run the InfinitySpring for 30 seconds and collect the remaining water in a glass.
- ▶ Remove the drawer.
- ▶ Turn the water tank all the way to the left and pull it out.
- ▷ Water dripping out is collected in the drip tray.
- ▶ Drain the water from the drip tray.
- ▶ Clean the drip tray with a cloth or in the dishwasher.

8.2.2 Inserting the water tank

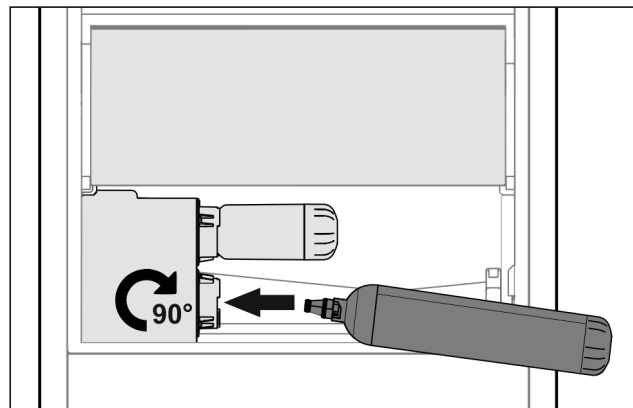

Fig. 59

- ▶ Remove the drawer.
- ▶ Insert the water tank and turn approx. 90° to the right until it engages.
- ▶ Check that the water tank is sealed and no water leaks out.
- ▶ Insert the drawer.
- ▶ Turn on the water tap.
- ▶ Vent the water system (see Installation Instructions, Water Connection)

Instead of the water filter, you can use an additional water tank.

Note

The water tank is available as a spare part.

8.2.3 Removing / inserting the drip tray

You can remove the drip tray for cleaning.

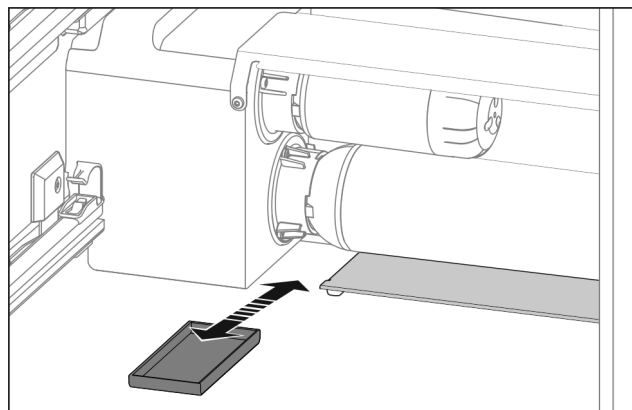

Fig. 60

- ▶ Pull out the drip tray to the front.

8.3 Water filter*

The water filter is located behind the lowest drawer.

It absorbs deposits in the water and reduces the taste of chlorine.

- Replace the water filter at least every 6 months under the specified usage conditions or if the flow rate drops significantly.
- The water filter contains carbon and can be disposed of with the regular household waste.

Note

The water filter can be purchased from the Liebherr-Hausgeräte store at home.liebherr.com/shop/de/deu/zubehor.html.

8.3.1 Removing the water filter

- ▶ Remove the drawer.
- ▶ Turn the water filter all the way counterclockwise and pull it out.
- ▷ Water dripping out is collected in the drip tray.
- ▶ Clean the drip tray with a cloth or in the dishwasher.

8.3.2 Installing the water filter

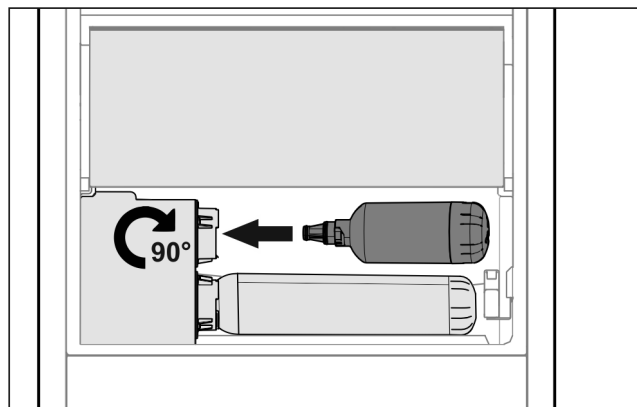

Fig. 61

- ▶ Remove the drawer.
- ▶ Insert the water filter and turn clockwise approx. 90° until it engages.
- ▶ Make sure the filter does not leak and no water is coming out.
- ▶ Insert the drawer.



CAUTION

New water filters may contain particulate matter.

- ▶ Dispense 3 l of water through the InfinitySpring and pour away.

- ▷ The water filter is now ready for use.

8.4 Disassembling / assembling pull-out systems

8.4.1 Notes on disassembly

You can disassemble some of the pull-out systems for cleaning. Your appliance can contain a variety of pull-out systems.

The following pull-out systems can be disassembled or cannot be disassembled:

Pull-out system	can be disassembled / cannot be disassembled
Full extension*	cannot be disassembled*
Partial pull-out fridge compartment*	cannot be disassembled*

8.5 Defrosting the appliance



WARNING

Appliance incorrectly defrosted!
Injuries and damage.

- ▶ Do not use mechanical devices or other means to accelerate the defrosting process, other than those recommended by the manufacturer.
- ▶ Do not use any electrical heating or steam cleaning equipment, naked flames or defrosting sprays.
- ▶ Do not remove ice with sharp objects.

Defrosting is performed automatically. The water from the thawing process runs out via the drain opening and is evaporated.

- ▶ Clean the drain opening regularly (see 8.7 Cleaning the appliance).

8.6 Defrosting the freezer compartment manually*

A layer of frost or ice forms after longer periods of operation.

The following factors may accelerate frost or ice formation:

- The appliance is opened frequently.
- Hot food is placed in the appliance.
- ▶ Switch off the appliance.
- ▶ Disconnect the power plug or fuse.
- ▶ Wrap the frozen food in newspaper or blankets and store in a cold place.

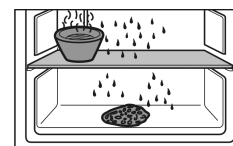

- ▶ Put a pot with hot (but not boiling) water on a middle shelf of the compartment.
- ▷ This speeds up defrosting.
- ▶ Leave the compartment and appliance doors open during defrosting.
- ▶ Remove pieces of ice that come loose.
- ▶ Make sure that the defrosted water does not run into the surrounding furnishings.
- ▶ If necessary, soak up the water with a sponge or a cloth several times.
- ▶ Clean the appliance (see 8.7 Cleaning the appliance).

8.7 Cleaning the appliance

8.7.1 Preparation



WARNING

Danger of electric shock.

- ▶ Unplug refrigerator or disconnect power.



WARNING

Danger of fire

- ▶ Do not damage the refrigerant circuit.

- ▶ Empty appliance.
- ▶ Pull out the power plug.

-or-

- ▶ Activate CleaningMode. (see CleaningMode)

Customer support

8.7.2 Cleaning the interior

NOTICE

Improper cleaning!

Damage to the appliance.

- ▶ Only use soft cleaning cloths and ph-neutral all-purpose cleaners.
- ▶ Do not use steel wool or sponges that scour or scratch.
- ▶ Do not use caustic or abrasive cleaning materials or those containing sand, chloride, or acids.

- ▶ Plastic surfaces: clean by hand with a soft clean cloth, lukewarm water and a little detergent.
- ▶ Metal surfaces: clean by hand with a soft clean cloth, lukewarm water and a little detergent.
- ▶ Drain hole: remove any deposits with a thin item such as a cotton bud.

8.7.3 Cleaning the equipment

NOTICE

Improper cleaning!

Damage to the appliance.

- ▶ Only use soft cleaning cloths and ph-neutral all-purpose cleaners.
- ▶ Do not use steel wool or sponges that scour or scratch.
- ▶ Do not use caustic or abrasive cleaning materials or those containing sand, chloride, or acids.

Clean with a soft, clean cloth, lukewarm water and a little washing up liquid:

- VarioSafe*
- Fruit & Vegetable-Safe cover
- Drawer
- Variable bottle shelf

Clean with a damp cloth:

- Retracting rails
Please note: the grease in the tracks is there for lubrication purposes and must not be removed!

Clean in the dishwasher up to 60 °C:

- Door racks
- VarioBox*
- Bottle rack
- Shelf
- Split shelf
- Holder for the split shelf
- HydroBreeze water tank and water tank lid*
- Drip tray*
- Egg rack
- Butter dish
- Ice cube tray*
- ▶ Disassemble the equipment: see the relevant section.
- ▶ Clean the equipment.

8.7.4 Cleaning the InfinitySpring*

You can clean the InfinitySpring outlet and around it without disconnecting the appliance from the mains.

We recommend cleaning in the following situations:

- Initial commissioning
- If out of use for longer than 5 days.
- ▶ Press the bottom pushbutton of the dispenser.
- ▷ The outlet unit moves out.
- ▶ Clean the water outlet and around it with a soft, damp cloth, lukewarm water and a little washing up liquid.
- ▶ Release the bottom pushbutton.
- ▶ Dispense 2 l of water through the InfinitySpring and pour away.*

8.7.5 Cleaning the HydroBreeze*

We recommend cleaning in the following situations:

- Initial commissioning
- HydroBreeze was off for longer than 48 hours.
- Refill the water tank.

Make sure that the following requirements are fulfilled

- HydroBreeze is off (see HydroBreeze*).
- Water tank was removed and cleaned in the dishwasher.
- ▶ Wipe out the recess with a damp cloth.
- ▶ Insert the water tank.
- ▶ Activate the HydroBreeze.

8.7.6 After cleaning

- ▶ Wipe dry the appliance and items of equipment
- ▶ Connect and switch on the appliance.
When the temperature is sufficiently cold
- ▶ Place the food inside.
- ▶ Repeat cleaning regularly.

9 Customer support

9.1 Technical specifications

Temperature zone	
Cool:	3 °C to 9 °C
BioFresh	0 °C to 3 °C

Maximum freezing capacity / 24 hrs	
Freezer compartment*	See nameplate, "Freezing capacity ... /24h"*

Max. size baking tray	
Width	466 mm
Depth	386 mm
Height	50 mm

Lighting	
Energy efficiency class ¹	Light source
This product contains one or more energy efficiency class G light sources.	LED

1 The appliance may contain light sources with different energy efficiency classes. The lowest energy efficiency class is indicated.

For appliances with a WiFi connection:*

Frequency specification*	
Frequency band	2.4 GHz
Maximum radiated power	<100 mW
Purpose of the wireless equipment	Integration in the local WiFi network for data communication

9.2 Operating noises

The appliance makes noises while in operation.

- At **less cooling output** the appliance saves energy but takes longer to cool items. The volume is **lower**.
- At a **higher cooling output** the food cools more quickly. The volume is **higher**.

Examples:

- Activated functions (see 6.3 Functions)
- Running fan
- Freshly sorted food
- High ambient temperature
- Door opened for long periods

Noise	Possible cause	Type of noise
Bubbling and splashing	Coolant is flowing into the cooling circuit.	Normal noise
Spitting and hissing	Coolant is spraying into the cooling circuit.	Normal noise
Humming	The appliance cools. The volume depends on the cooling output.	Normal noise
Sipping noises	The self-closing door is being opened and closed.	Normal noise
Whirring and murmuring	The fan is running.	Normal operating noise
Clicking	Components are being switched on and off.	Normal switching noise

Noise	Possible cause	Type of noise
Rattling or humming	Valves are active.	Normal switching noise

Noise	Possible cause	Type of noise	How to resolve
Vibration	Unsuitable installation	Error noise	Check installation. Set up the appliance.
Clattering	Equipment, Objects inside the appliance	Error noise	Secure equipment parts. Leave a gap between items.

9.3 Technical faults

Your appliance is designed and manufactured for reliable operation and a long service life. If a malfunction nonetheless occurs during operation, please check whether the malfunction is due to an operating error. In this case, you will have to be charged for the costs incurred, even during the warranty period.

You may be able to rectify the following faults yourself.

9.3.1 Appliance function

Defect	Cause	Remedy
The appliance does not work.	→ The appliance is not switched on.	▶ Switch on the appliance.
	→ The power plug is not properly inserted in the wall socket.	▶ Check the power plug.
	→ The powerfuse in the wall socket is not OK.	▶ Check the fuse.
	→ Power failure.	▶ Keep the appliance closed. ▶ Protect your food: Lay freezer packs on top of the food or use another freezer if the power is off for a prolonged period. ▶ Do not re-freeze defrosted food.
	→ The appliance connector is not correctly inserted in the appliance.	▶ Check the appliance connector.
The temperature is not cold enough	→ This means that the door of the appliance is not closed properly	▶ Close the appliance door
	→ Insufficient ventilation	▶ Clear and clean the ventilation grille.
	→ The ambient temperature is too high	▶ Solution: (see 1.4 Range of appliance use) .
	→ The appliance was opened too frequently or for too long	▶ Wait to see whether the required temperature resets itself by itself. If not, contact Customer Service (see 9.4 Customer service) .
	→ The temperature is incorrectly set	▶ Set to a colder temperature and check after 24 hours.
	→ The appliance is too near to a heat source (stove, heater etc).	▶ Change location of appliance or the heat source.
	→ The appliance was not properly installed in the recess.	▶ Make sure the appliance was installed correctly and the door closes properly.
The door seal is defective or should	→ The door seal is interchangeable. You can replace it without the use of any special tools.	▶ Contact Customer Service (see 9.4 Customer service) .

Customer support

Defect	Cause	Remedy
be replaced for other reasons.		
The appliance is iced up or condensation is building.	→ The door seal may have slipped out of its groove.	▶ Check the door seal is well placed in the groove.

9.3.2 Equipment

Defect	Cause	Remedy
The InfinitySpring is not working.*	→ There is air in the system.	▶ Vent the water system (see Installation Instructions, Water Connection).
	→ The water connection is not open	▶ Open the water connection*
The water flow at the InfinitySpring is irregular.*	→ The aerator is not clean.	▶ Replace the aerator. Contact Customer Service (see 9.4 Customer service) .
HydroBreeze is not keeping refrigerated foods moist.*	→ HydroBreeze is not activated.	▶ Activate the HydroBreeze.
	→ There is not enough water in the water tank	▶ Fill the water tank.
	→ There is dirt upstream of the concentrator.	▶ Clean the HydroBreeze.
	→ The water tank is not properly locked into place.	▶ Make sure the water tank clicks in properly.
	→ The lid of the Fruit & Vegetable-Safe is set to "low air moisture".	▶ Adjust the lid of the Fruit & Vegetable-Safe to "high air moisture".
The interior light does not turn on.	→ The appliance is not switched on.	▶ Switch on the appliance.
	→ The door was open for longer than 15 min.	▶ The interior light automatically switches itself off if the door stays open for approx. 15 min.
	→ The LED interior light is faulty or the lid is damaged.	▶ Contact Customer Service (see 9.4 Customer service) .
The freezer door will not shut.*	→ The catch is locked with the door open.	▶ Try the handle again.

9.4 Customer service

First check if you can fix the error yourself (see 9 Customer support) . If this is not the case, please contact customer service.

Please refer to the enclosed "Liebherr Service" brochure for the address.



WARNING

Unprofessional repair!
Injuries.

- ▶ Repairs and work on the appliance and the power supply cable not described in the Manual (see 8 Maintenance) should only be carried out by a qualified service provider.
- ▶ A damaged power cable may only be replaced by the manufacturer, the manufacturer's Customer Service or a similarly qualified person.
- ▶ For appliances with an IEC connector, the change can be made by the customer.

9.4.1 Contact Customer Service

Make sure to have the following appliance information to hand:

- Appliance name (model and index)
- Service no. (service)
- Serial no. (S no.)
- ▶ Showing appliance info on the display (see Info) .
- or-
- ▶ Referring to appliance info on the nameplate (see 9.5 Rating plate) .
- ▶ Take note of the appliance information.
- ▶ Inform Customer Service: Tell us the problem and the appliance details.
- ▷ This will help us give you fast and accurate support.
- ▶ Further instructions from customer service will follow.

9.5 Rating plate

The nameplate is located behind the drawers on the inside of the appliance.

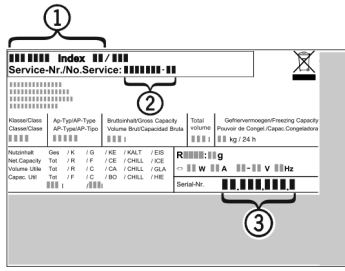

Fig. 62

- (1) Appliance name (3) Serial no.
 (2) Service no.
 ► Information from the nameplate.

For Germany:

You can dispose of the appliance free of charge via the class 1 collection containers at the local recycling and recyclable material collection centers. When purchasing a new fridge/freezer, if the sales area > 400 m², retailers will also take back the old appliance free of charge.



WARNING

- Leaking refrigerant and oil!
 Fire. The refrigerant contained within the appliance is environmentally friendly, but flammable. The oil contained within the appliance is flammable. Escaping refrigerant and oil can ignite if they are of high enough concentration and are exposed to an external heat source.
- Do not damage the pipelines of the coolant circuit and the compressor.
 - Transport the appliance away without damaging it.
 - Dispose of batteries, lamps, and the appliance according to the above specifications.

10 Decommissioning

- Empty appliance.
- Switch off the appliance .
- Pull out the power plug.
- Remove the appliance connector if necessary: Pull it out and, at the same time, move it from the left to the right.
- Clean the appliance (see 8.7 Cleaning the appliance) .
- Leave the door open to prevent bad smells

11 Disposal

11.1 Preparing appliance for disposal



Li-Ion

Liebherr uses batteries in some of its appliances. In the EU, for environmental reasons, legislation obliges the end user to remove these batteries before disposing of the old appliances. If your appliance contains batteries, a corresponding notice is attached to the appliance.

Lamps If you can remove the lamps yourself without destroying them, also remove these before disposal.

- Take the appliance out of operation.
- Appliance with batteries: Remove the batteries. For description, see **Maintenance** chapter.
- If possible: Remove lamps without destroying them.

11.2 Disposing of the appliance in an environmentally friendly manner



The appliance still contains valuable materials and must be collected separately from unsorted municipal waste so it can be recycled.



Li-Ion



Li-Ion

Dispose of batteries separately from the old appliance. You can do this by returning the batteries free of charge to retailers or taking them to recycling centers and collection centers for recyclable materials.

Lamps Dispose of removed lamps via the respective collection systems.



home.liebherr.com/fridge-manuals

EN Built-in refrigerator with BioFresh

Issue date: 20230118

Part number index: 7088276-00

Liebherr-Hausgeräte GmbH
Memminger Straße 77-79
88416 Ochsenhausen
Deutschland