



iQ700, built-in microwave, 60 x 38 cm, Stainless steel BE634LGS1M



38 cm high built-in microwave for defrosting, reheating or preparation of dishes in the shortest possible time.

- ✓ Automatic programs ensure best results - cookControl10.
- ✓ TFT Display: good readability from any perspective.
- ✓ Wattage: time-saving and powerful up to 900 watts.
- ✓ Ideal for elevated installation - side-opening hinged door.
- ✓ Foods are evenly browned by the powerful grill.

Features

Technical Data

Type of micro-wave oven : MW+Grill function
Type of control : Electronic
Color / Material Front : Stainless steel
Dimensions : 382 x 594 x 318 mm
Cavity dimensions : 220 x 350 x 270 mm
Length electrical supply cord : 150 cm
Net weight : 18.4 kg
Gross weight : 20.6 kg
Maximum micro-wave power : 900 W
Number of Power Levels : 5
Turntable : No
Cavity material : Stainless steel
Door opening : Button
Clock : Yes
Included accessories : 1 x grid, 1 x Glass tray
Main colour of product : Stainless steel
Height of the product : 382 mm
Width of the appliance : 594 mm
Depth of the product : 318 mm
Maximum micro-wave power : 900 W
Connection Rating : 1990 W
Fuse protection : 10 A
Voltage : 220-240 V
Frequency : 60; 50 Hz
Plug type : GB plug
Color / Material Front : Stainless steel
Required cutout/niche size for installation (in) : x x
Dimensions of the packed product : 18.50 x 18.11 x 26.37
Net weight : 40.000 lbs
Gross weight : 45.000 lbs
Included accessories : 1 x grid, 1 x Glass tray

Included accessories

- 1 x grid
- 1 x Glass tray





iQ700, built-in microwave, 60 x 38 cm, Stainless steel BE634LGS1M

Features

Design:

- Cavity volume: 21 l
- stainless steel cavity with glass bottom
- User-friendly electronics: extremely
- easy and comfortable operation

Comfort:

- Touch control
- electronic clock
- automatic programming, 10
- Open Button, electric
- Touch key operation
- side opening door, hinge left
- LED light

Accessory:

- 1 x Glass tray, 1 x grid

Environment and Safety:

- start button
- door contact switch

Microwave and Heating System

- Max. Power: 900 W; 5 Microwave power settings: 90 W, 180 W, 360 W, 600 W, 900 W
- Intelligent inverter technology: maximum output power will be regulated to 600 W when used in longer operation
- Grill and microwave power levels 90 W, 180 W, 360 W combinable
- Microwave and grill for separate use and in
- Kombination nutzbar
- Integral cooling fan

Technical Info:

- Nominal voltage: 220 - 240 V
- Total connected load electric: 1.99 KW
- Length of mains cable: 150 cm
-
- Appliance dimension (hxwxd): 382 mm x 594 mm x 318 mm
- Niche dimension (hxwxd): 362 mm - 382 mm x 560 mm - 568 mm x 300 mm
- Can be built in a 60 cm wall cupboard (at least 30cm deep)
- "Please reference the built-in dimensions provided in the installation drawing"



**iQ700, built-in microwave, 60 x 38 cm,
Stainless steel
BE634LGS1M**

Dimensioned drawings

measurements in mm

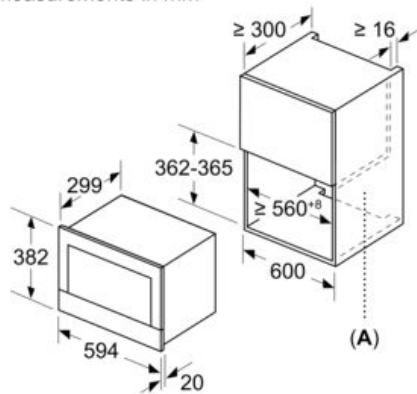

A: Back panel open

measurements in mm

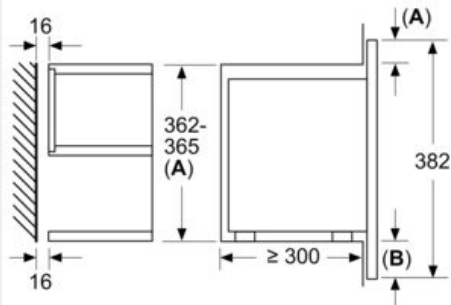

A: Overhang at top:

Recess 362: 6 mm

Recess 365: 3 mm

B: Overhang at bottom: 14 mm

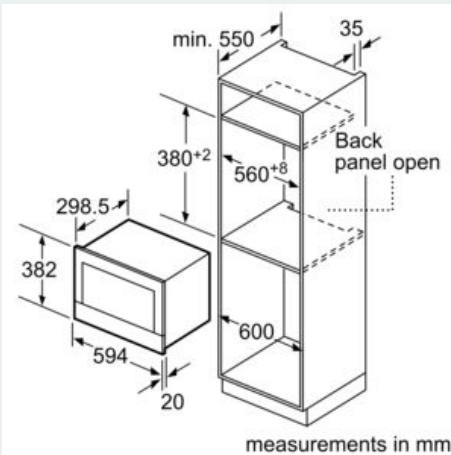

measurements in mm